

KEITH

WALKING FLOOR®

WE MOVE YOUR
BUSINESS FORWARD

CleenSweep® - Manual (CSM)

WALKING FLOOR® International

www.WalkingFloorService.ca

Canada

Brantford, ON

Toll-Free: 800-514-6085

Phone: +1-519-756-9178



KEITH Manufacturing Co.

www.KeithWalkingFloor.com

World Headquarters

Madras, OR

Toll-Free: 800-547-6161

Phone: +1-541-475-3802

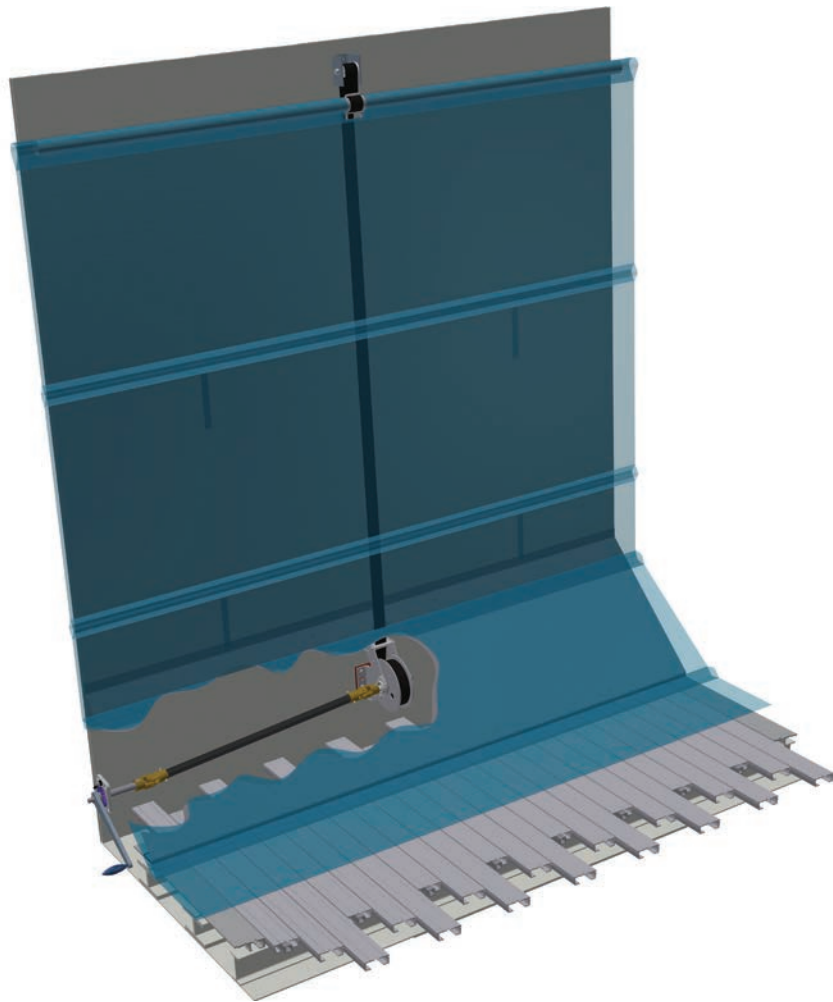

INSTALLATION / OWNER'S MANUAL & PARTS CATALOG

Original Instructions

©2026 KEITH Manufacturing Co. All Rights Reserved. KEITH, KEITH logo and WALKING FLOOR are registered trademarks of KEITH Manufacturing Co. Equipment manufactured by KEITH Manufacturing Co. is protected by numerous patents both domestic and foreign.63

Released: 2026-04-01

DOC06950 Rev. D

Table of Contents

Introduction iii

CleenSweep® Tarp System Limited Warranty iv

Warranty Registration Card v

1.0 Safety 1

 1.1 General Safety 1

 1.1.1 Intended Function and Expected Use: 1

 1.1.2 Improper Use 1

 1.1.3 Training 1

 1.1.4 Personal Protective Equipment 1

 1.2 Design / Installation Safety 1

 1.2.1 Controls 1

 1.3 Marking of Machinery 2

 1.3.1 Safety Decals 2

2.0 Specifications 3

 2.1 System 3

 2.2 Component Identification 4

3.0 Installation 5

 3.1 Strap Roller Mounting Position Options 5

 3.2 Winch & Strap Roller Installation 6

 3.2.1 Winch Installation Below Slope Shield 6

 3.2.2 Strap Roller Assembly Installation Near Top of Front Wall 8

 3.2.3 Strap Roller Assembly Installation Under Front Tarp Header 9

 3.2.4 Option for High Density or High Flow Materials 10

 3.3 Tarp Assembly, Installation & Adjustment 11

 3.4 Tarp Modifications for Bullnose Trailer 15

 3.5 Tarp Modifications for V-Floor Trailers 16

 3.6 Optional - Tarp Catcher™ 16

4.0 Step by Step Instructions 17

5.0 Winch Brake Adjustment - Wedge Brake 29

6.0 Operation 30

7.0 Troubleshooting 32

 7.1 Check List 32

 7.2 Problem / Solution - Troubleshooting 32

8.0 Parts Catalog 33

 Winch Assembly 33

 Strap Roller Assembly 36

 Tarp & Misc Components 37

 Tarp Catcher™ 38

9.0	Technical Support	39
10.0	Contact Information - KEITH Manufacturing Co.	39
11.0	Crank Handle Mounting Plate Template	40

Introduction

This manual explains procedures for installing and operating the KEITH® Manual CleenSweep® Tarp System. Many variables affect the installation, but the general process remains constant. Details of the installation vary, according to trailer features and installer preferences.

An efficient installation requires appropriate tools and accessible materials that are not supplied with this kit.

It is strongly recommended that the installers and operators read this entire manual before beginning the installation or operating of the system.

Please direct any questions to KEITH Manufacturing Co., one of our international offices listed in the contact information section of this manual, or on our website.

 **WARNING:** Always disconnect hydraulic and electric power to the trailer and follow lock out/tag out safety procedures before entering the trailer or working on the CleenSweep® Tarp System components. Failure to do so may result in serious injury or death.

IMPORTANT: Installing the CleenSweep® Tarp System requires some alterations to your trailer. Changes made without the approval of the trailer manufacturer may void the trailer's warranty.

CleenSweep® Tarp System Limited Warranty

This CleenSweep® Tarp System is warranted to the original purchaser to be free from defects in material and workmanship under normal use for a period of **one year** from the date of purchase. During the warranty period, and upon proof of purchase, the CleenSweep® Tarp System will be repaired or replaced with the same or similar model.

IT IS EXPRESSLY AGREED THAT THIS SHALL BE THE SOLE AND EXCLUSIVE REMEDY OF THE BUYER. UNDER NO CIRCUMSTANCES SHALL KEITH MANUFACTURING CO. BE LIABLE FOR ANY COSTS, LOSS, EXPENSE, DAMAGE, SPECIAL DAMAGES, INCIDENTAL DAMAGES, OR CONSEQUENTIAL DAMAGES ARISING DIRECTLY OR INDIRECTLY FROM THE USE OF THE CLEENSWEEP® TARP SYSTEM. WHETHER BASED UPON WARRANTY, CONTRACT NEGLIGENCE OR STRICT LIABILITY.

THE WARRANTY AND LIMITS OF LIABILITY CONTAINED HEREIN ARE IN PLACE OF ALL OTHER WARRANTIES AND LIABILITIES, EXPRESSED OR IMPLIED. ALL IMPLIED WARRANTIES OF MERCHANTABILITY AND FITNESS FOR A PARTICULAR PURPOSE ARE HEREBY DISCLAIMED BY KEITH MANUFACTURING CO. AND EXCLUDED FROM THIS WARRANTY. FURTHER, KEITH MANUFACTURING CO. DOES NOT WARRANT THAT THE CLEENSWEEP® TARP SYSTEM COMPLIES WITH LOCAL, MUNICIPAL, STATE OR FEDERAL CODES, IF ANY AND THE BUYER ALONE IS RESPONSIBLE FOR ANY KNOWLEDGE OF ANY COMPLIANCE WITH ANY SUCH CODES.

This warranty shall not apply to any parts that; (a) have been repaired or altered outside of the CleenSweep® Tarp System; (b) have been subjected to misuse, negligence or accident; or (c) have been used or installed in a manner contrary to CleenSweep® Tarp System instructions.

In certain circumstances some states do not allow the exclusion or limitation of incidental damages, some or all of the above limitations or exclusions may not apply to you. This warranty gives you specific legal rights and you may have other rights that vary from state to state.

If this warranty violates law: To the extent any provision of this warranty contravenes the law of any jurisdiction, that provision shall be inapplicable in such jurisdiction and the remainder of the warranty shall not be affected thereby.

Notice: To validate all warranties, a warranty registration card must be completed and returned to KEITH Manufacturing Co. within ten days of purchase. If you did not receive a warranty registration card, contact your dealer immediately.

Warranty Registration Card

Note: To validate the warranty, the registration information must be filled out completely and returned to KEITH within ten (10) days of purchase and/or installation.

Please fill out the Warranty Registration form on our website at www.KeithWalkingFloor.com or fill out the Warranty Registration Card below and mail or email it to:

KEITH Manufacturing Co.
 401 NW Adler St.
 Madras, OR 97741

TechDept@KeithWalkingFloor.com

This warranty registration card must be completed and on file at KEITH in order for the warranty period to begin on the purchase date. If no purchase date is registered, the beginning of the warranty will automatically revert to the manufacture date.

Name / Company Name: _____

Address: _____

City, State / Prov.: _____ Postal Code: _____

Country: _____

Phone: _____

E-Mail: _____

SYSTEM DATA:

Date of Purchase: _____

Model / Serial Number: _____

Purchased From: _____

Type of Material Loaded/Unloaded: _____

I have fully read the KEITH Manufacturing Co. warranty information and fully understand and agree to the terms of the warranty.

Name: _____ Date: _____ Signature: _____

1.0 Safety

1.1 General Safety

1.1.1 Intended Function and Expected Use:

- 1.1.1.1. The KEITH® CleenSweep® system is a winch system primarily intended to restage clean out systems used in live floor trailers. The system is supplied as a kit primarily intended for installation into mobile trailers or truck bodies. It is manually operated.

1.1.2 Improper Use

- 1.1.2.1. This equipment has been manufactured utilizing state-of-the-art technology in accordance with acknowledged safety regulations. Nevertheless, dangerous situations could arise from improper use, which could endanger life and limbs of personnel and cause damage to the equipment and other assets. This equipment may only be used for its intended purpose. It may only be operated in impeccable technical condition and in accordance with the proper use and this user manual. Problems, which could affect safety, must be resolved immediately. The manufacturer is not liable for any damage caused by improper use or arbitrary modifications. The installation, commissioning, operation, and maintenance instructions must be followed as outlined in this manual.
- 1.1.2.2. Personnel must not enter the danger zone(s) when the system is enabled. Specifically, nobody should be inside, under, or behind the trailer in the unloading zone during operation. Additionally, no one should be in a full or filling trailer. Lock-out and tag-out procedures must be followed before accessing the drive area.
- 1.1.2.3. Safeguards must not be altered or bypassed.
- 1.1.2.4. The user and system designer must understand the characteristics and safe handling requirements of the material that is being conveyed.
- 1.1.2.5. Bulk materials are by nature unstable and flowable. Avoid burial by avoiding contact with the material.

1.1.3 Training

- 1.1.3.1. Operators must read and understand this manual before operating or maintaining the machine. Only qualified, trained personnel may execute commissioning, operation, and maintenance of the system.

1.1.4 Personal Protective Equipment

- 1.1.4.1. Always wear protective equipment appropriate for risks associated with each phase of the system's life, including transportation, installation, assembly, operation, inspection, maintenance, and dismantling, disabling, and scrapping. As a minimum, this includes the following personal protective equipment:
 - Safety Glasses
 - Protective/Traction Shoes
 - Gloves
 - Welding/Grinding Protection
 - Helmets
 - Thermal Protection (i.e. Coats)
 - Hearing Protection

1.2 Design / Installation Safety

1.2.1 Controls

- 1.2.1.1. The control panel must be located such that it is easily accessible for all sizes and capacities of people, and allows the operator to move freely (whenever applicable).
- 1.2.1.2. Control devices must be located outside of danger zones, such that any exposed persons in danger zones are visible from the control station.
- 1.2.1.3. An acceptable means must be provided to monitor the status and movement of the load.

1.3 Marking of Machinery

1.3.1 Safety Decals

Safety Decal Placement Guide: CleanSweep - Manual





The guide displays three types of safety decals:

- 1**: Brand logo decal: KEITH® CLEANSWEEP® TARP SYSTEM
- 2**: General safety warning decal: Features a yellow triangle warning symbol, a hand being cut by a blade, a person being struck, and a person using a tool.
- 3**: Specific machinery warning decal: Features a yellow triangle warning symbol, a hand being cut by a blade, a person being struck, a person using a tool, and a person using a tool.

The 3D cutaway diagram illustrates the placement of the safety decals on the machinery:

- 1**: The brand logo decal is placed on the side panel of the machinery.
- 2**: The general safety warning decal is placed on the side panel of the machinery.
- 3**: The specific machinery warning decal is placed on the side panel of the machinery.

KEITH Manufacturing Co. www.KeithWalkingFloor.com Rev B

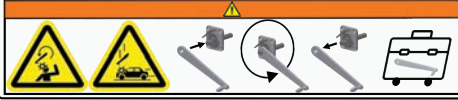
<u>Worded</u> Old - 2019	<u>Wordless</u> 2020 - Future	<u>Description</u>
		Rotating parts and shaft can cut or entangle causing serious injury. Stay clear when in operation. Lockout/tagout before servicing.
		KEITH CleenSweep Tarp System
		Remove handle when not in use and store in secure compartment when traveling.

* Some or all of these safety decals may apply and be adhered to this system.

2.0 Specifications

2.1 System

Manual CleenSweep®	
Dimensions	7.25"W x 10.5"H x 9.25"D [184 mm x 267 mm x 235 mm]
Weight	25 lbs [11 kg]

2.2 Component Identification

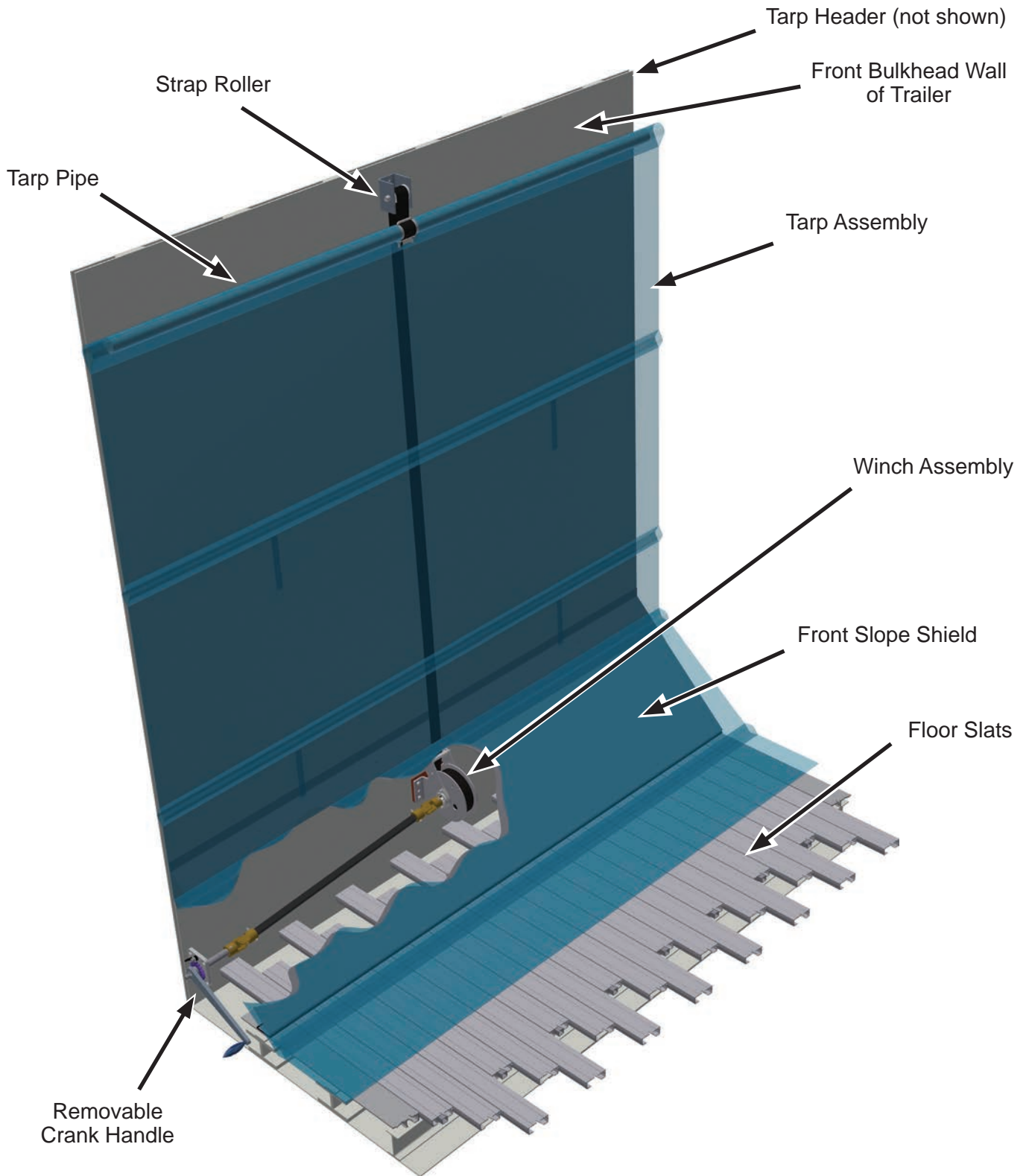

3.0 Installation

3.1 Strap Roller Mounting Position Options

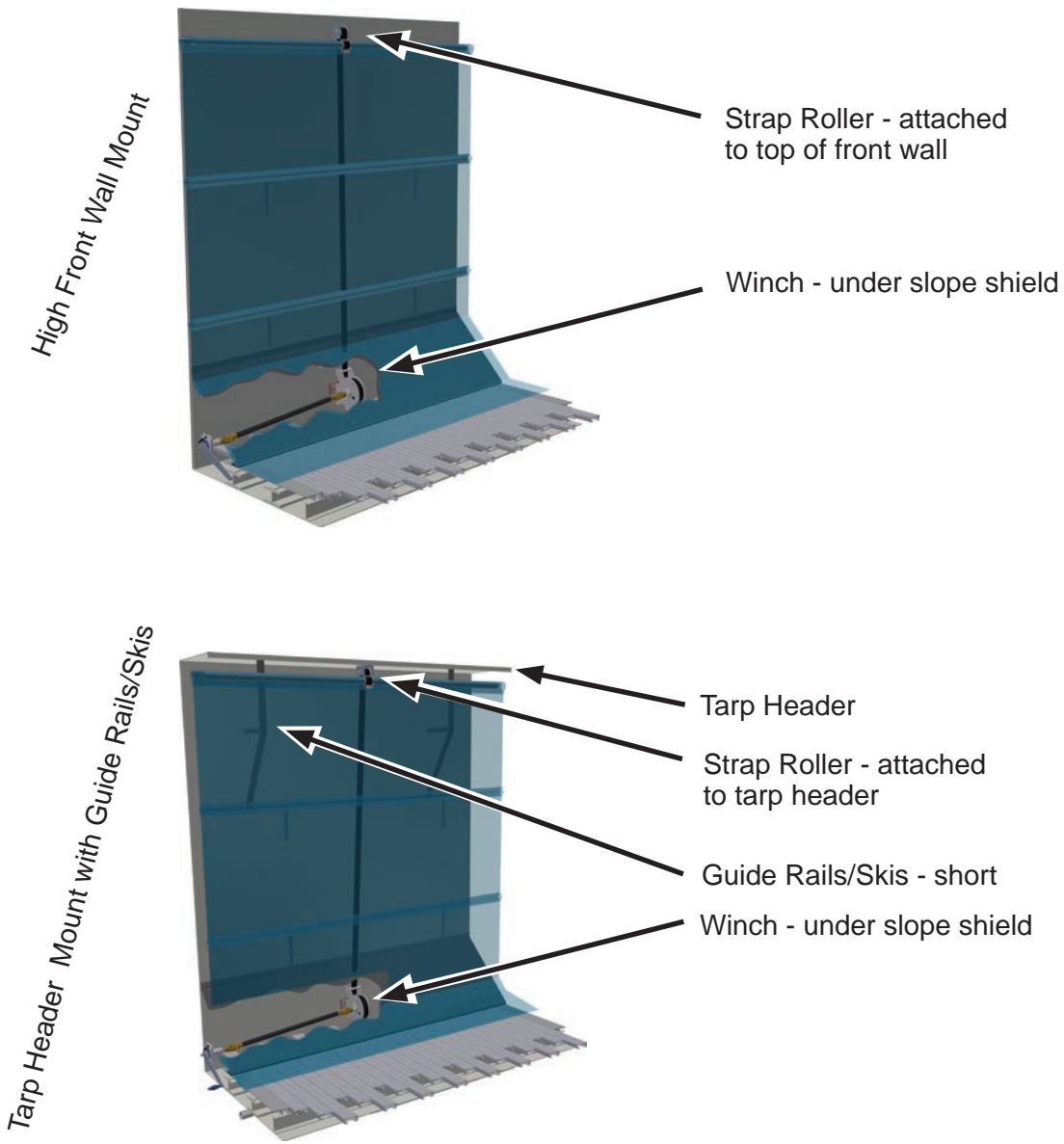

⚠ WARNING: Always disconnect hydraulic and electric power to the trailer and follow lock out/tag out safety procedures before entering the trailer or working on the CleenSweep® Tarp System components. Failure to do so may result in serious injury or death.

3.2 Winch & Strap Roller Installation

Winch mounted on front wall below front slope shield and strap roller mounted near top of front wall.

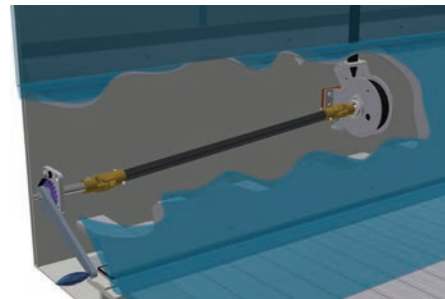
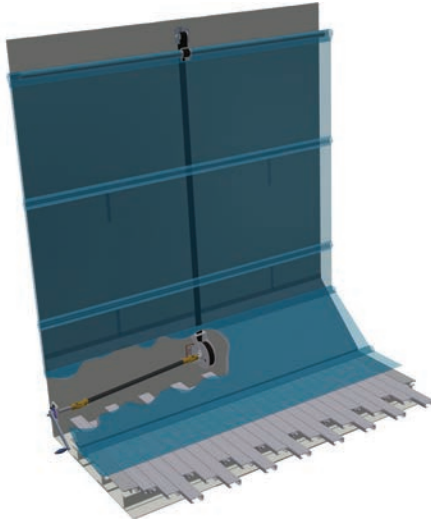

3.2.1 Winch Installation Below Slope Shield

NOTE: Front wall of trailer may need to be reinforced to withstand the forces created by the winch.

1. Locate and mark a centerline up the front wall of the trailer. **NOTE:** It is crucial that strap roller and the roll of strap on the winch is mounted in the absolute center of the trailer. If the winch is not mounted square, it will put uneven pressure on the tarp strap and the system will not function properly.

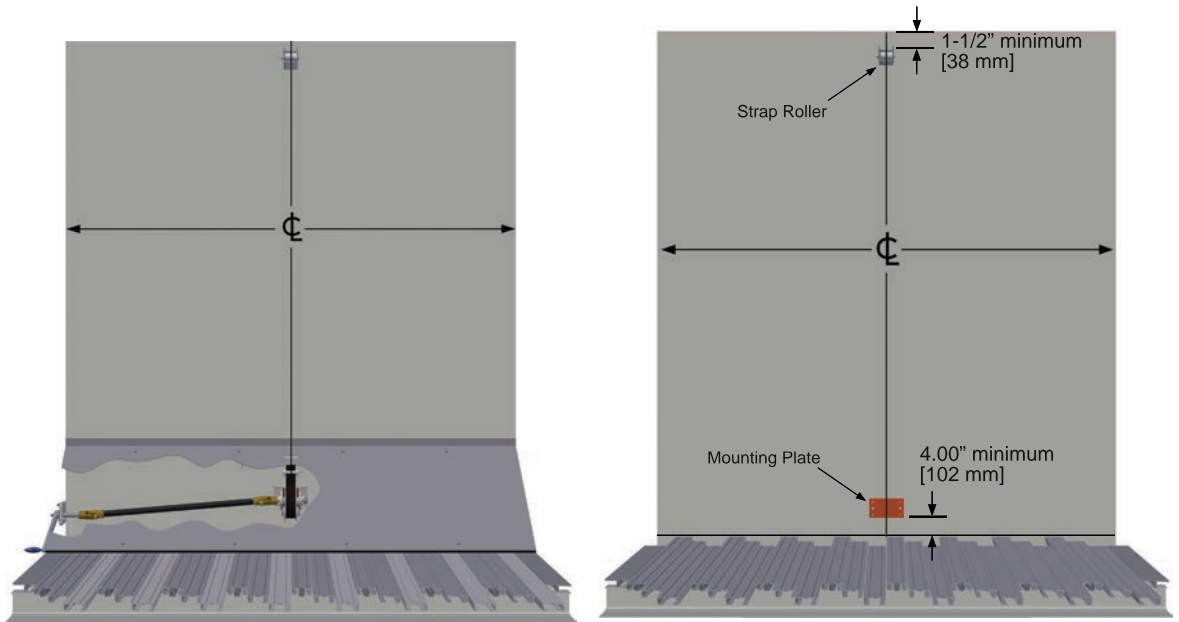

- The winch must not interfere with the operation of the floor slats, and there should be a 1" [25mm] minimum clearance between the winch and slats. Ensure all moving parts of the winch and floor have adequate clearance. Measure 4" [102 mm] up from the top of the floor slats to locate the bottom of the mounting plate.

A. WELD ATTACHMENT: Remove the winch mounting plate from the winch assembly, center on the front wall and weld. Then re-attach winch assembly to mounting plate using the (4) M10 bolts.

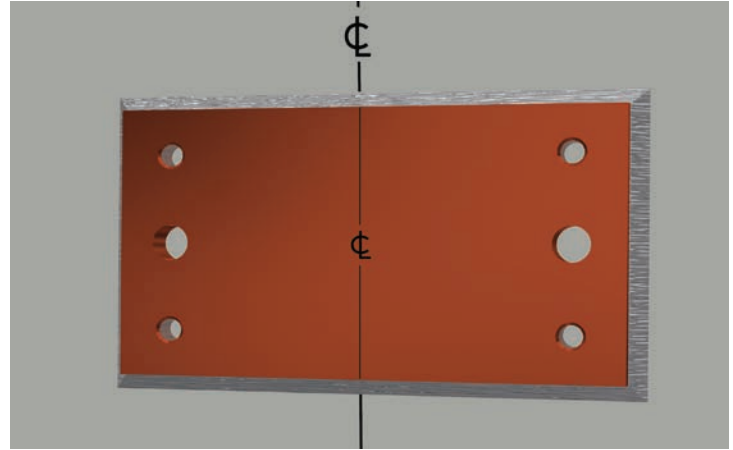

B. BOLT ATTACHMENT: Transfer the winch mounting plate mounting bolt hole pattern to the wall and drill (2) 17/32" [13 mm] bolt clearance holes. Then attach the entire winch assembly to the trailer wall using (2) 1/2" grade 8+ [M12 class 10.9+] locking fasteners (not included).

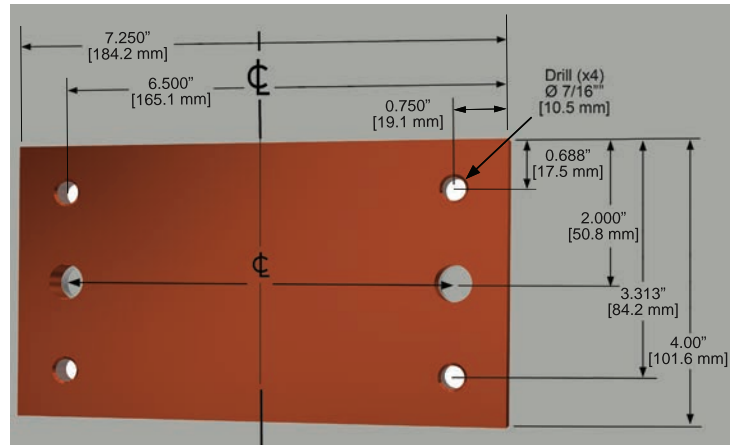

- Front shield modification: It is recommended that the front shield be hinged or fitted with a door/panel to gain access to the winch after it is installed to facilitate adjustment, inspection and maintenance.
- An opening must be cut into the front Slope Shield and a UHMW strap guide installed for the strap to pass through. The opening must be centered along the path of the strap from the winch to the strap roller assembly.

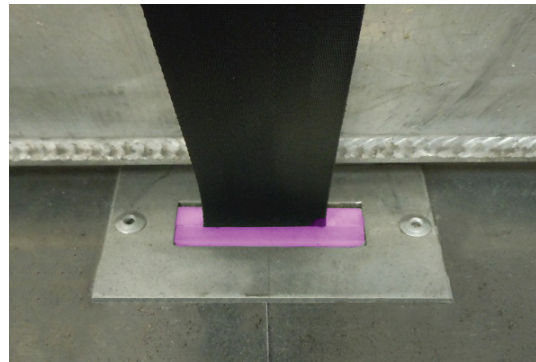
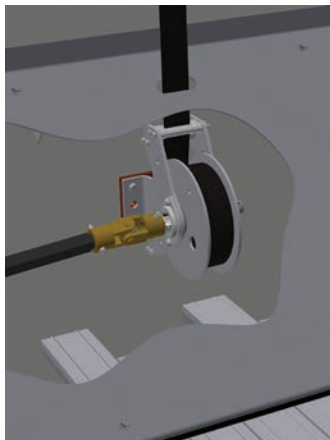

3.2.2 Strap Roller Assembly Installation Near Top of Front Wall

NOTE: Front wall of the trailer may need to be reinforced to withstand the forces created by the winch.

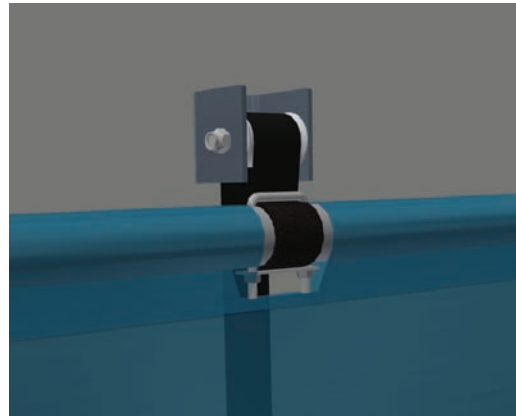

1. Locate the centerline at the top of the front wall of the trailer.

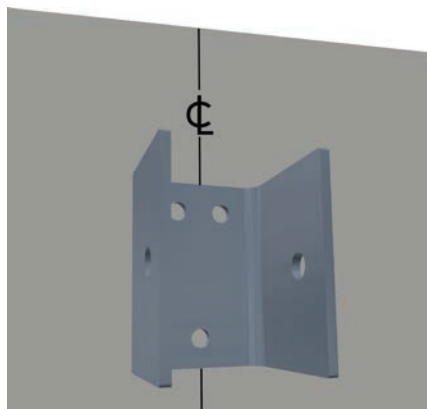

2. Measure down a minimum of 1-1/2" [38 mm] from the top to locate the strap roller mounting bracket.
3. Center the strap roller bracket with the two mounting holes toward the top of the wall and weld in place or transfer the strap roller bracket bolt pattern to the wall and drill (3) 7/16" [11 mm] bolt clearance holes.
4. Attach the strap roller to the front wall using (3) 3/8" grade 5+ [M10 class 8.8+] locking fasteners.

3.2.3 Strap Roller Assembly Installation Under Front Tarp Header

If the trailer has any obstacles on the front wall, such as broom/shovel hooks, or man door handles/hinges, then tarp guide rails/skis will need to be fabricated and installed. Guide rails/skis guide the tarp away from the front wall to avoid contact with these obstacles, thus preventing possible tarp damage. Also, the strap roller will need to be attached under a Front Tarp Header and in line with the guide rails/skis to allow the tarp to hang straight down and against the ski/guide rails.

NOTE: Front wall of the trailer and tarp header may need to be reinforced to withstand the forces created by the winch.



1. Locate and mark the centerline of the tarp header.

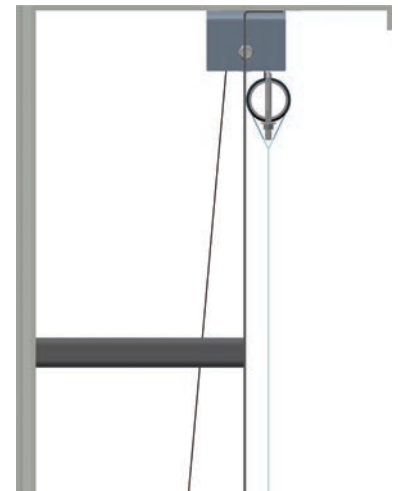
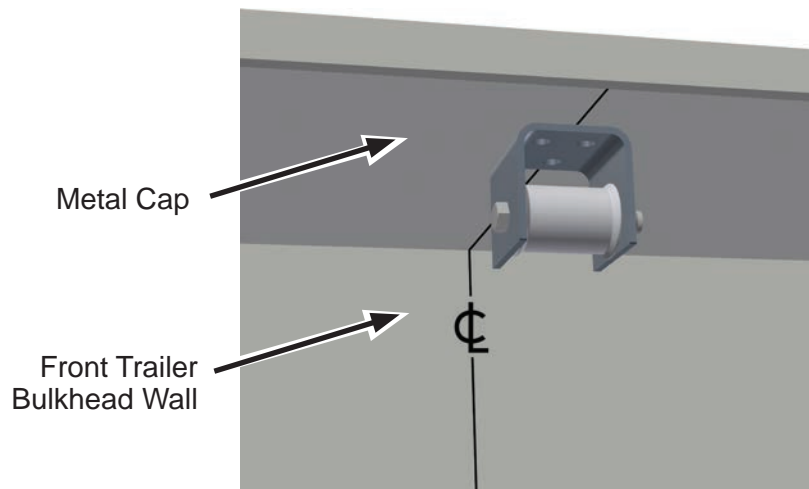

2. Locate the strap roller bracket far enough out from the front wall so that the tarp will hang straight down along the outside of the tarp guide rails when it is fully retracted. (See image)
3. Center the strap roller bracket with the two mounting holes toward the rear of the trailer and weld in place or transfer the strap roller bracket bolt pattern to the wall and drill (3) 7/16" [11 mm] bolt clearance holes.
4. Attach the strap roller to the tarp header using (3) 3/8" grade 5+ [M10 class 8.8+] locking fasteners.

3.2.4 Option for High Density or High Flow Materials

A. High Sided Trailer with Sloped Tarp Header:

- Prevents material from getting behind the tarp while loading and from getting stuck on top of tarp header.

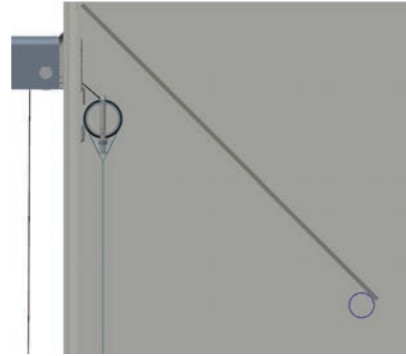
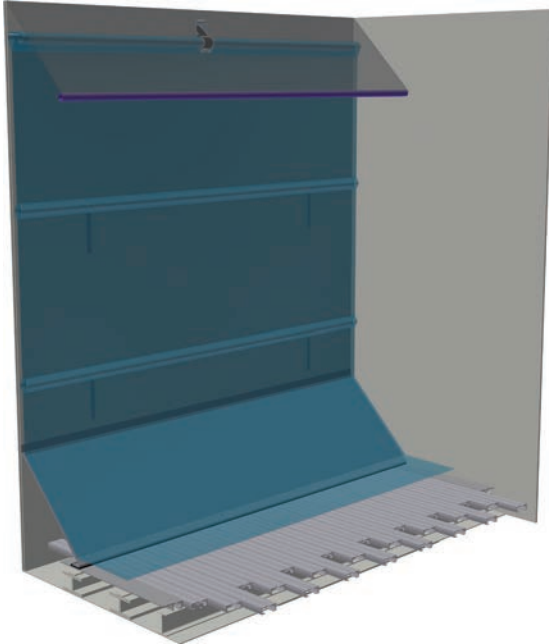

3.3 Tarp Assembly, Installation & Adjustment

Please note that pipes, strips and fasteners are not supplied by KEITH Manufacturing Co. For the top pocket, located at the top of the tarp when fully retracted and hanging, (1) 2" [50 mm] diameter lightweight metal conduit pipe is recommended. For all other pockets, use 1-1/2" [40 mm] diameter lightweight metal conduit pipes or 1/4" x 3" [6 mm x 76 mm] UHMW plastic strips.

1. Cut the pipes/strips approximately 2" [50 mm] shorter than the inside width of the trailer. Take this measurement just above the trailer floor, at the trailer's narrowest point.
2. If the tarp is wider than the width of the trailer, cut the tarp to the same width as the inside of the trailer. Remove half of the material from each side of the tarp.

Note: If you are installing the tarp into a trailer with a V-Floor® system or into a bullnose trailer, the tarp will need to be wider than the inside of the trailer because the tarp will conform to the ridges on the floor or the nose of the trailer. See Tarp Modifications for V-Floor Trailers for additional instructions.

If using Pipe in lower pockets:

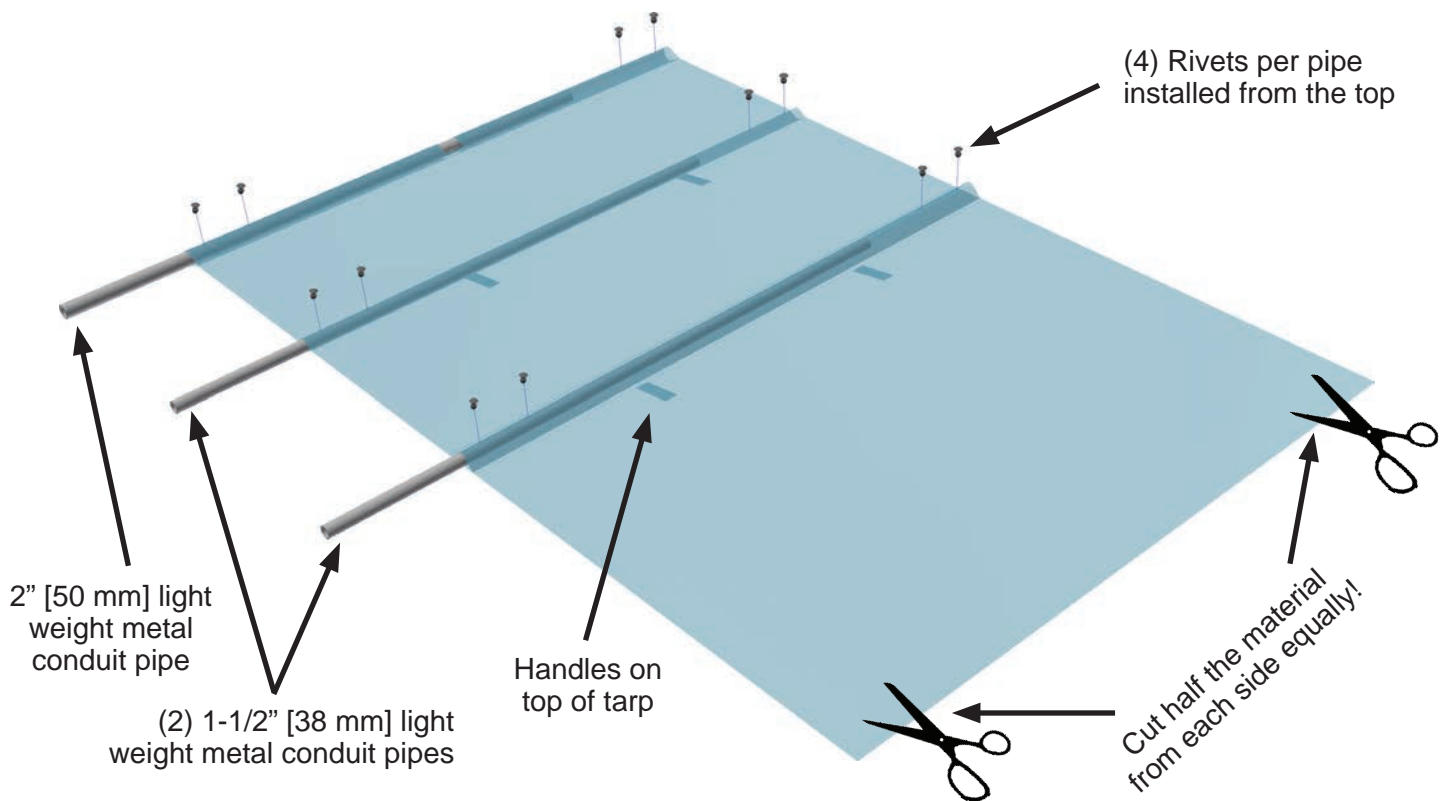

- C. With the tarp laying down on the floor of the trailer, center the 2" [50 mm] pipe in the top pocket of the tarp which has the notch cut out in the center. On the top side of the pipe drill (4) holes through the tarp and pipe and install rivets (not supplied) to hold the pipe in place.
- D. Center the smaller diameter pipes in the lower pockets of the tarp. On the top side of the pipes drill (4) holes through the tarp and pipes and install rivets (not included) to hold the pipes in place.

If using UHMW strips in lower pockets:

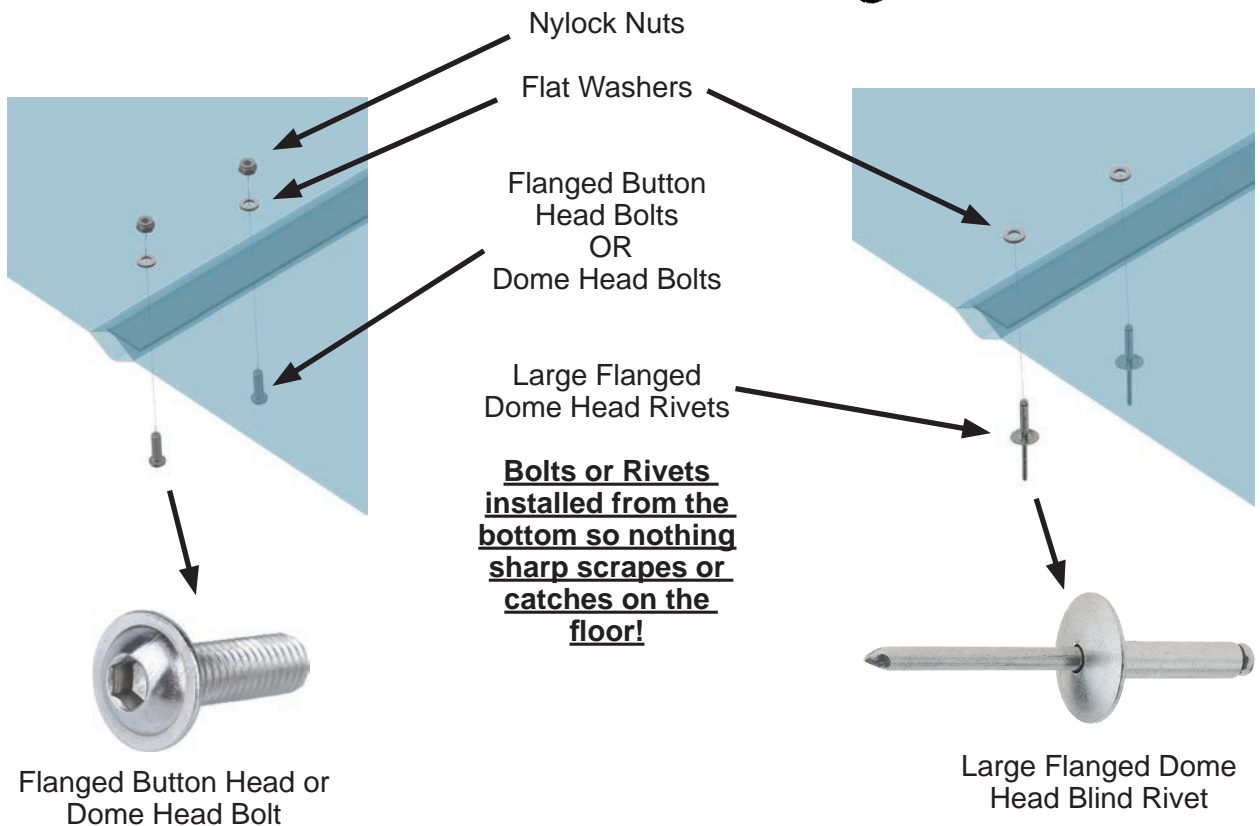
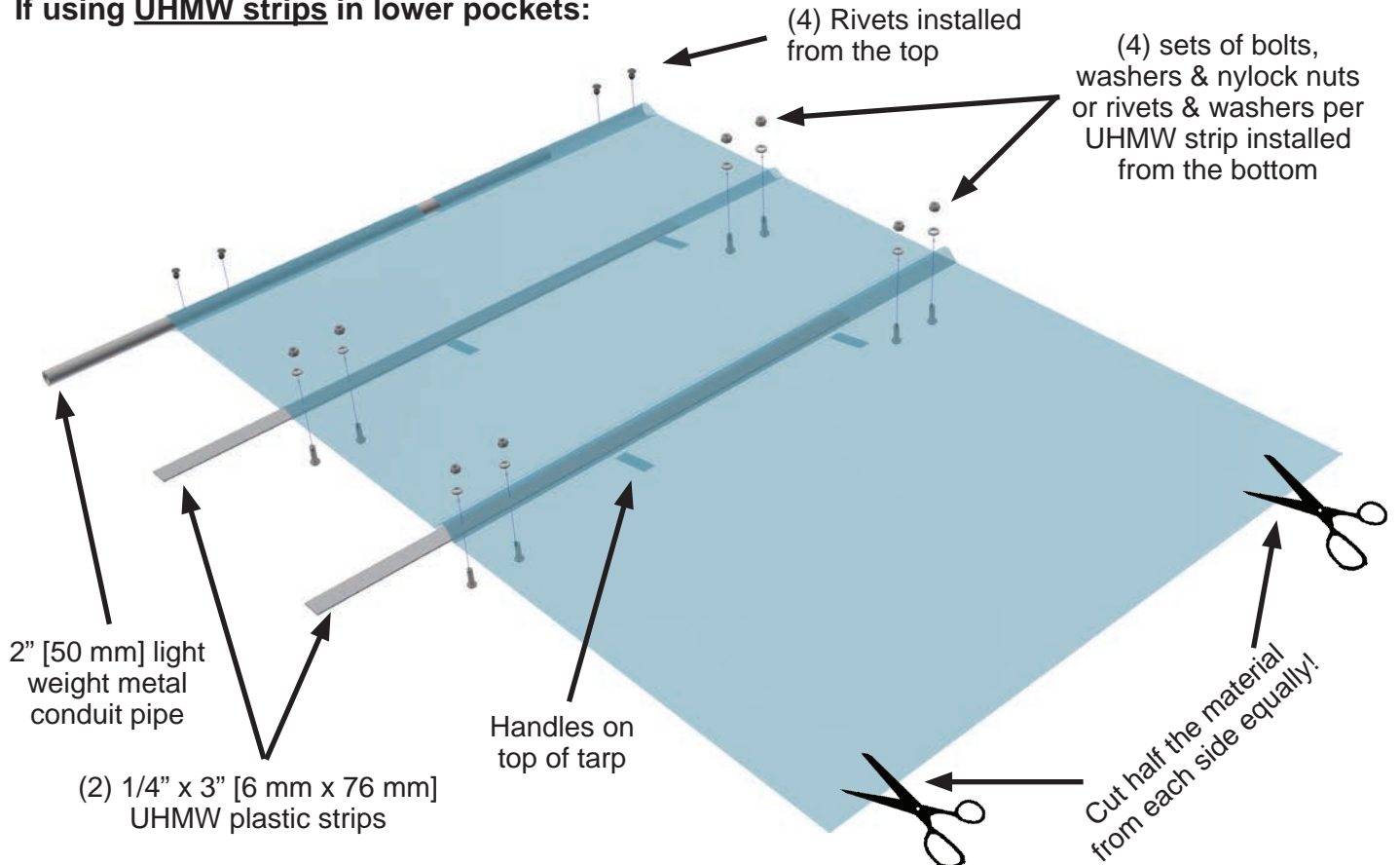

- A. With the tarp laying down on the floor of the trailer, center the 2" [50 mm] pipe in the top pocket of the tarp which has the notch cut out in the center. On the top side of the pipe drill (4) holes through the tarp and pipe and install rivets (not supplied) to hold the pipe in place.
 - B. Center the UHMW strips in the lower pockets of the tarp. Drill (4) holes completely through the tarp and UHMW strips. Use bolts with washers and nylock nuts (not supplied) or use rivets with washers (not supplied) to keep the UHMW strips in place. Bolts or Rivets should be installed from the bottom so nothing sharp scrapes or catches on the floor.
3. Find the center of the top pipe when the tarp is in the hanging position. Drill (2) 3/8" [9.5 mm] holes, evenly spaced, through the top pipe to attach the U-bolt. It must be centered and installed so that when the tarp is hanging from the winch, the threads of the U-bolt are facing downward. If necessary, you can make the notch in the tarp wider in the middle to accommodate the U-bolt.
 4. Retract all slats to the front of the trailer. Lay the tarp in the rear of the trailer, with the handles on top of the tarp and the 2" [50 mm] top pipe resting inside of the trailer just before the end of the slats. This will be where the tarp stops during unloading with the rest of the tarp hanging off the back of the trailer.
 5. Release the winch strap brake and thread the strap through the strap guide on the winch, through the UHMW strap guide in the front shield and through the strap roller. Pull (unwind) all of the loose strap completely off of the winch, so the attachment screws are visible, and stretch it out past the end of the trailer, making sure that the strap is not twisted.

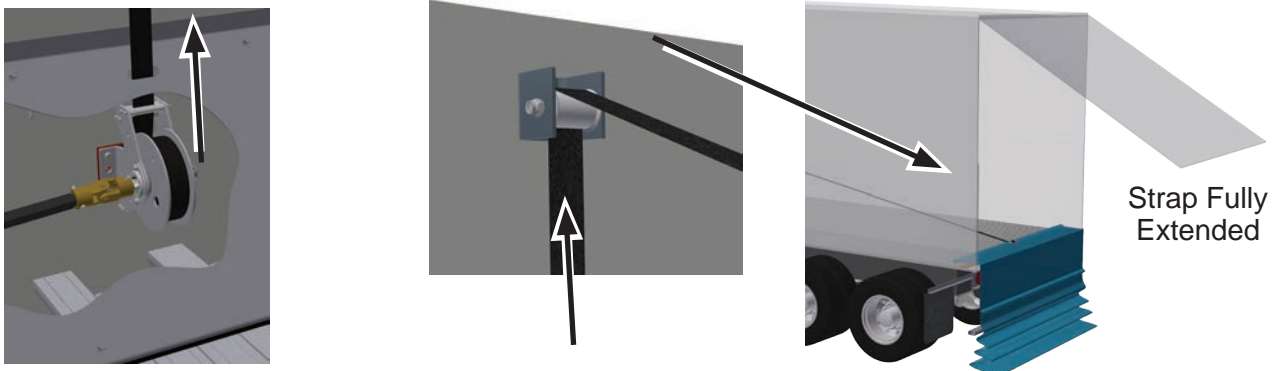

6. Cut the strap off, leaving enough strap to wrap loosely under the u-bolt, around the top pipe, around the u-bolt plate and back up under the u-bolt. Pull tight and tighten the U-bolt to hold the strap securely in place. This will keep the top pipe of the tarp from falling out of the trailer when the strap is fully extended.

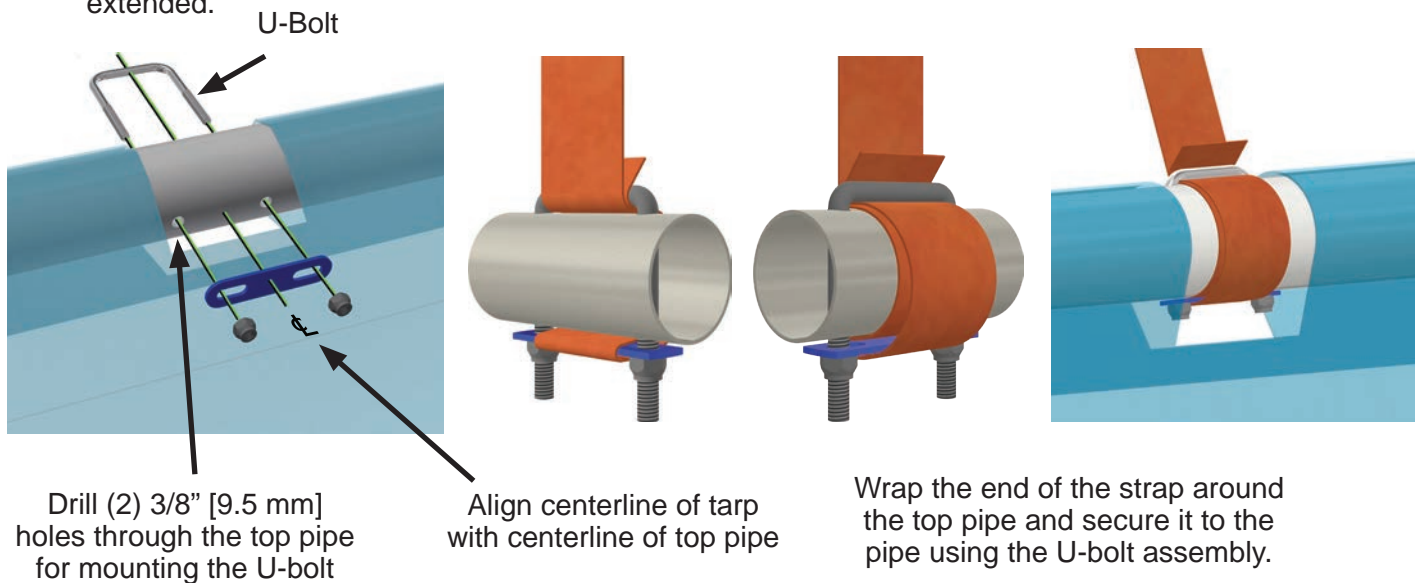

7. Retract the tarp assembly completely so that the U-bolt is back to the strap roller. Cut the tarp to length leaving a minimum of 12"-14" [305-356 mm] of tarp on the floor covering the slats. Too much tarp on the floor and the tarp will get caught in the unloaded material and be difficult to remove. Too little tarp on the floor and it won't move along with the load and sweep cleanly. Additional tarp on the floor (36"-48" [914-1219 mm]) may be needed if the material being unloaded is very light weight (low density).

Top of Tarp - Retracted

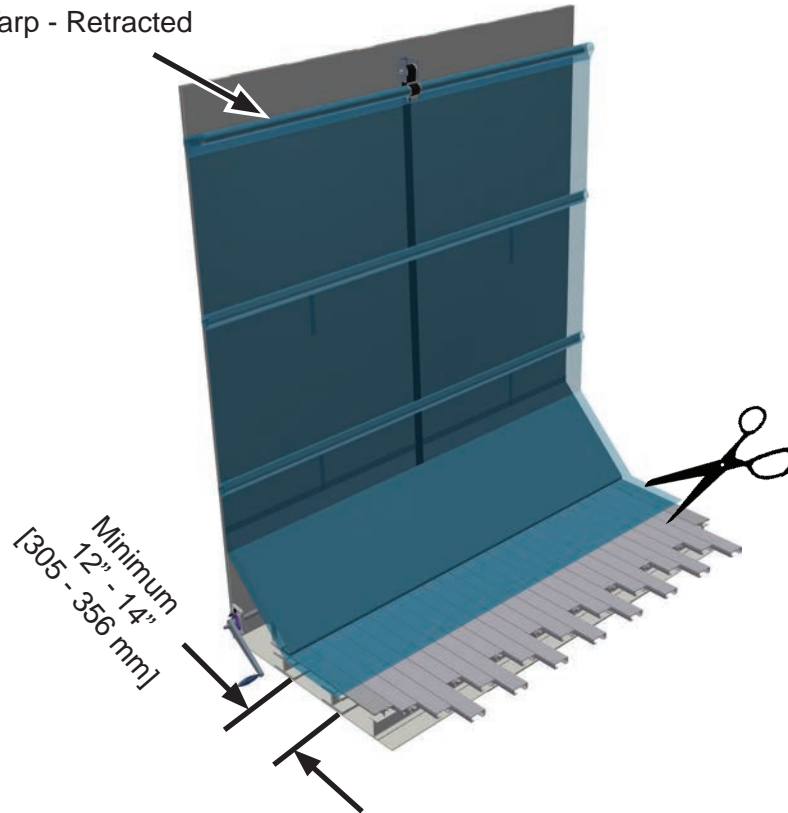

3.4 Tarp Modifications for Bullnose Trailer

NOTE: Front wall and tarp header of the trailer may need to be reinforced to withstand the forces created by the winch.

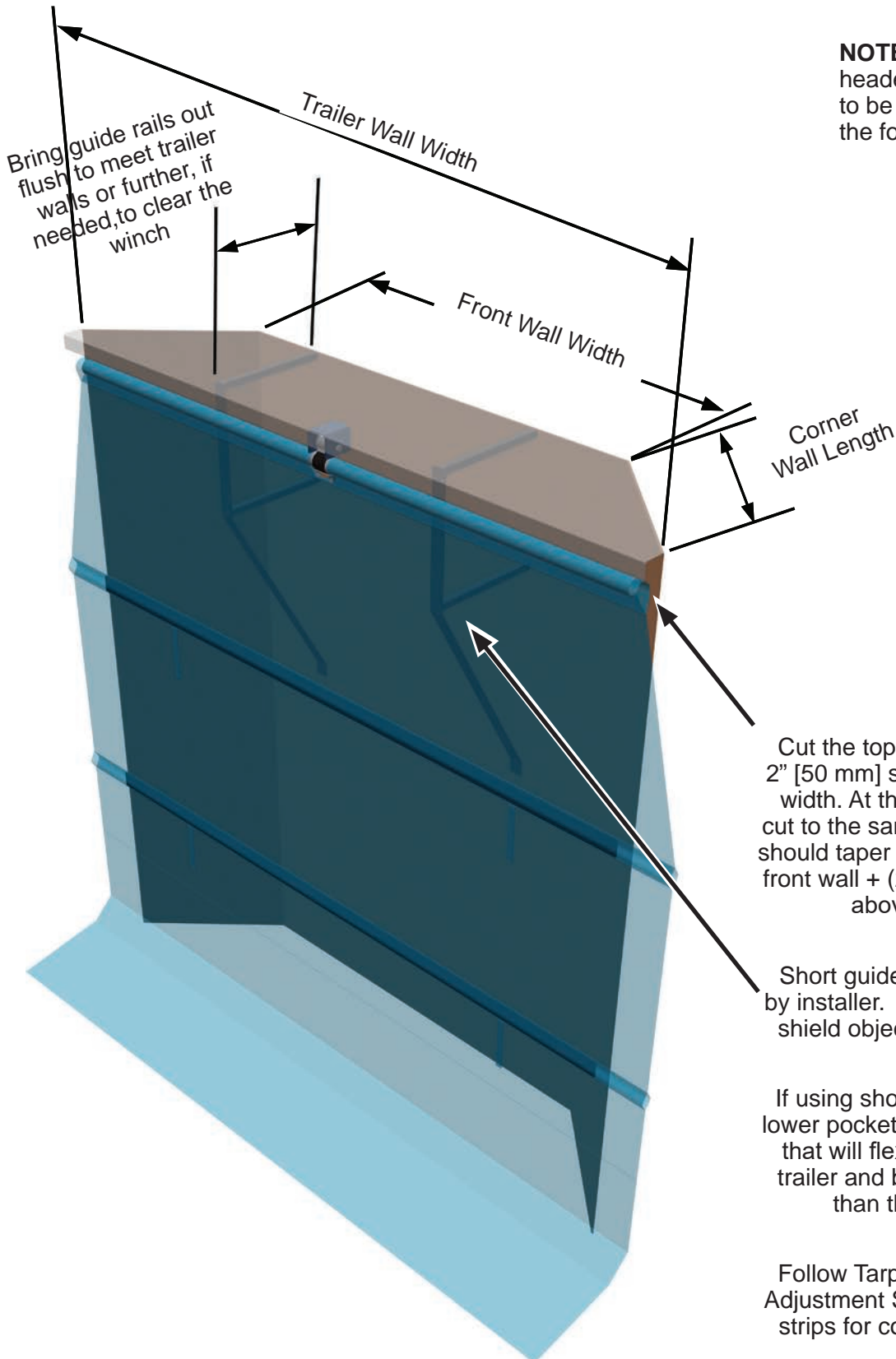

3.5 Tarp Modifications for V-Floor Trailers

Note: If you are installing the tarp into a trailer with a V-Floor® system or into a bullnose trailer, the tarp will need to be wider than the inside of the trailer because the tarp will conform to the ridges on the floor or the nose of the trailer. For a V-9 system, the tarp should be approximately 6" [152 mm] wider than the inside of the trailer. For a V-18 system, the tarp should be approximately 7" [178 mm] wider.

- A. Start in the middle of floor and place weights or (gravel, dirt, etc) on the tarp between all the slats to hold the tarp down so it conforms to all of the slats.
- B. Cut both sides of the tarp **equally** along the trailer wall so that the tarp is now the same width as the trailer.

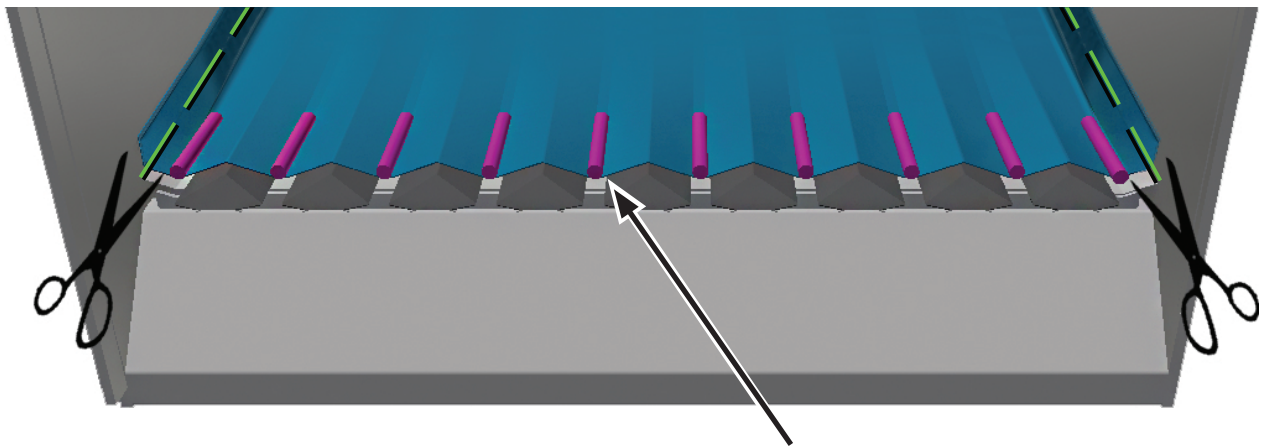

Example of weights

3.6 Optional - Tarp Catcher™

Installing a tarp catcher on the end of the trailer will catch and hold the tarp and make sure that it doesn't get buried in the load.

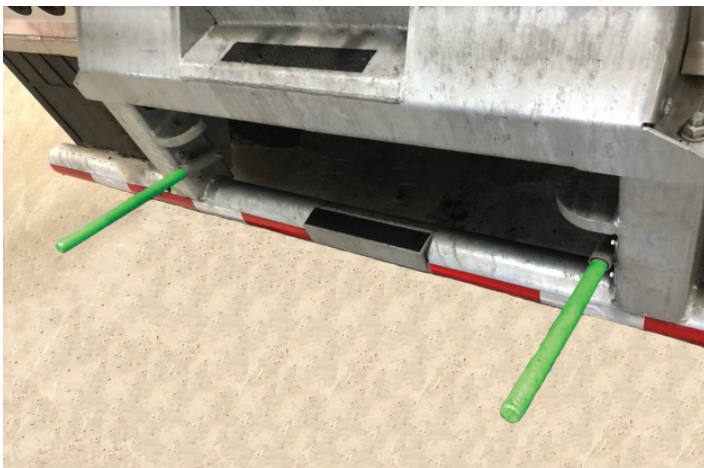

4.0 Step by Step Instructions

1. Remove the **slope shield**.

Remove any **objects** that will interfere with the operation of the tarp system.

If **broom and shovel holders** are installed and can't be remove, guide rails/skis will have to be installed to protect the tarp from catching or tearing.



2. Measure the width of the trailer and mark the centerline on the front trailer wall with a permanent marker for future reference.

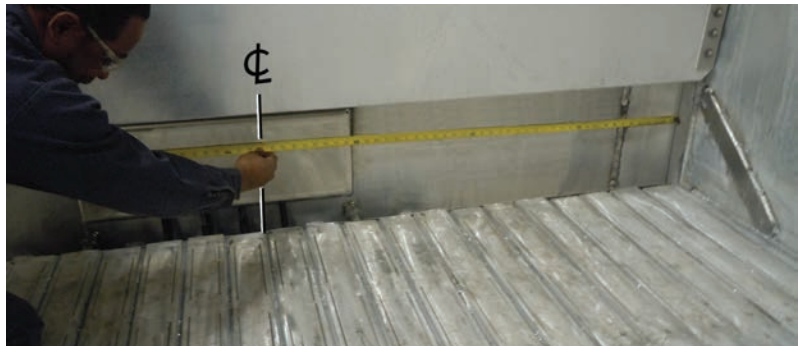

3. Align center of winch **base plate** with center mark on trailer.

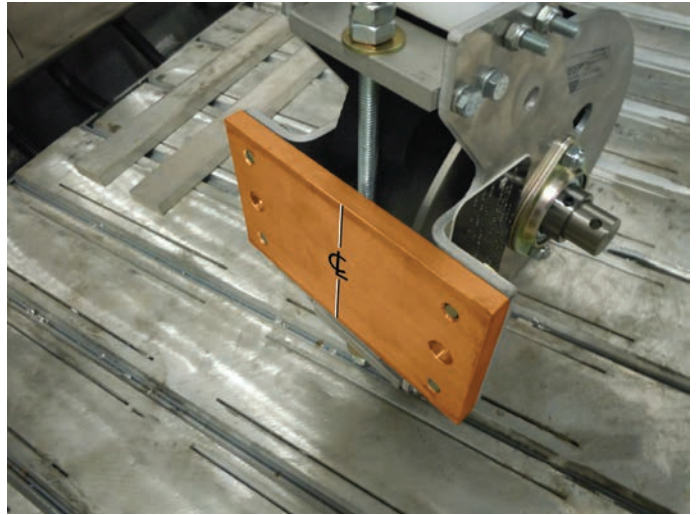

4. Measure 4" [102 mm] up from the top of the floor slats to locate the bottom of the mounting plate or place a **spacer** (~1" [25 mm] thick) at the bottom of the winch spool to keep winch placed at proper height.



5. If trailer has an **electrical box** underneath the slope shield, **weld** winch base plate to the exterior wall of the box.

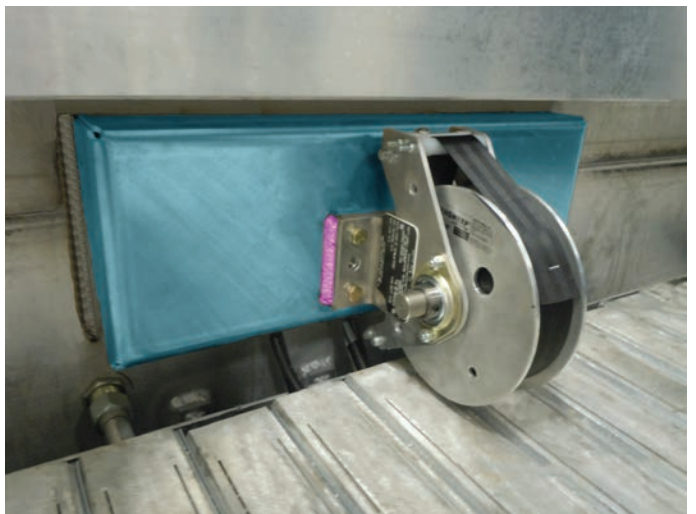

6. If trailer does not have an electrical box underneath the slope shield, place centered winch, without base, on the inside wall of the trailer.



7. Place winch **base plate** on exterior of front wall and bolt winch in place.
Note: Extended fastening hardware NOT included.



8. Use the handle mounting plate template inside the trailer (included) to ensure the bolts will be placed in an area that will not interfere with something inside the trailer when drilled from the exterior.



9. Mark appropriate measurement as reference on exterior of trailer.

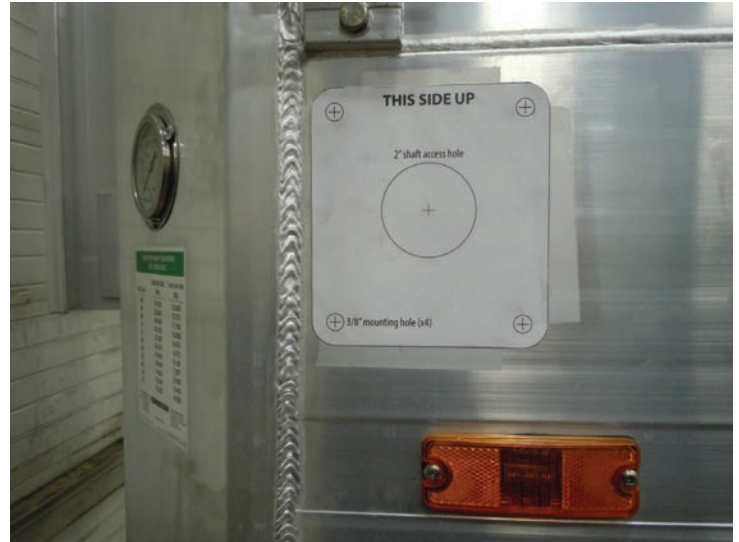

10. Use measurement from interior to place template in appropriate area. Center punch all indicated areas to be drilled.



11. Hole cut/drill all necessary holes, following sizes outlined on template.



12. Once holes are drilled, place the handle assembly in the appropriate fashion.

Note: Attachment Hardware NOT included.

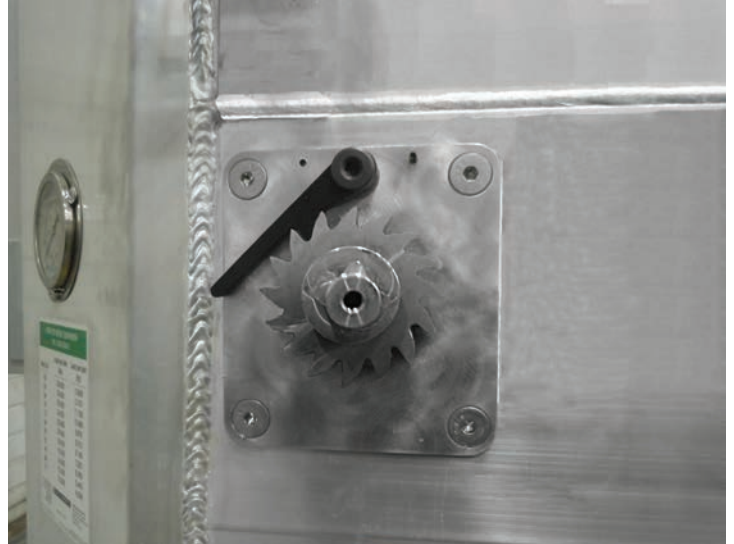

13. Fasten the handle assembly on the interior of the trailer with appropriate washers and lock nuts.

Note: Attachment hardware NOT included.



14. Connect **drive shaft** to both the handle assembly and winch assembly with supplied hardware.

Top up **areas with grease** by using the grease nipples attached and continue to do so on regular intervals.

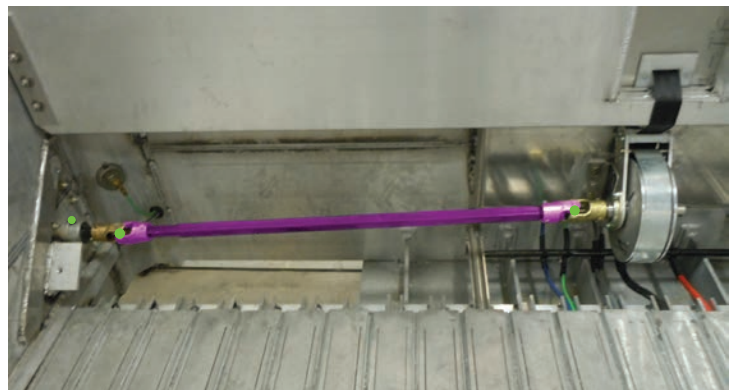

15. If the winch assembly does not properly fit underneath the slope shield, adjustments will need to be made to the slope shield. A hole may need to be cut through the slope shield with a riser fabricated to create a gap over the spool and strap guides.



16. See image of additional slope shield fabrication to compensate for a protruding winch assembly. Be sure that the winch spool can rotate freely.

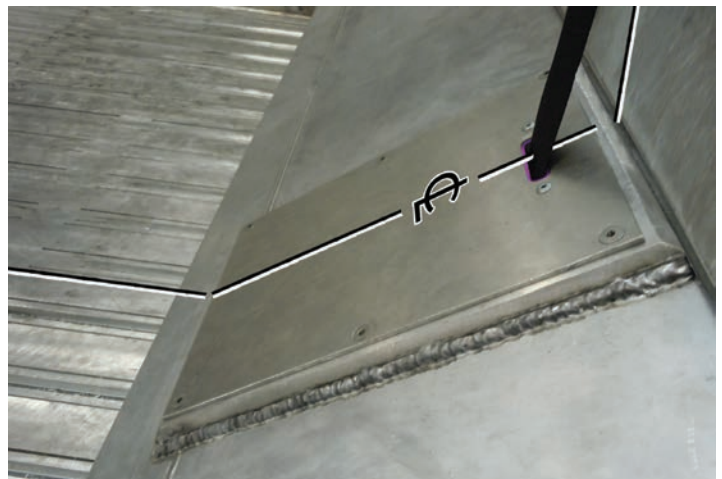
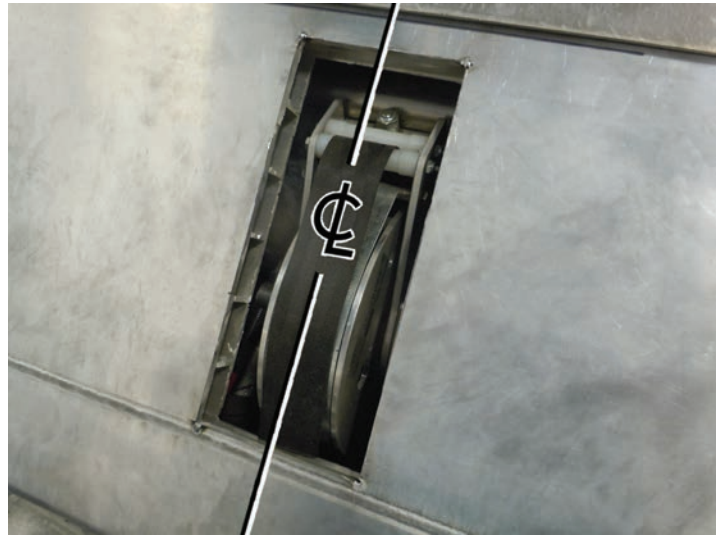

17. If the winch assembly fits underneath the slope shield, an opening must be cut into the front slope shield and a UHMW **strap guide** installed for the strap to pass through. The opening must be centered along the path of the strap from the winch to the strap roller assembly.

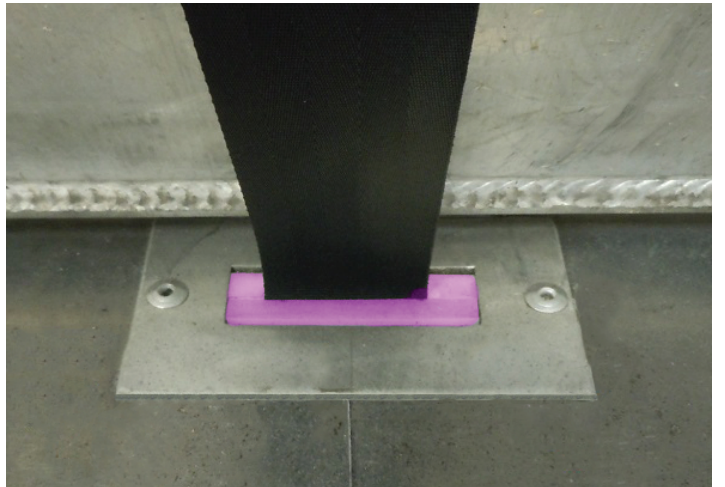
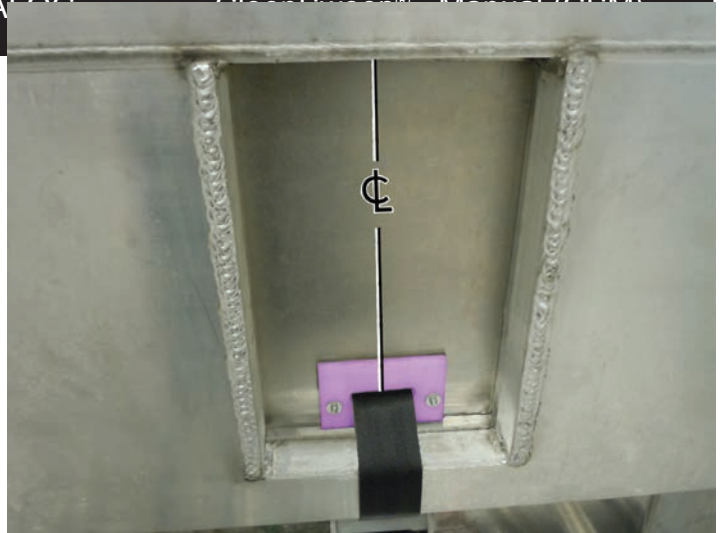

18. If trailer has **broom/shovel hooks** on the front wall that can't be removed, **guide rails/skis** will need to be fabricated. Guide rails/skis keep the tarp from contacting the tool hooks, preventing possible tarp/tarp stiffener damage.



19. Install **strap roller** as high as possible on the front wall (mounting hardware not included) to allow the retracted tarp to rest at the maximum height possible.

Or

If **guide rails/skis** are needed, mount strap roller under a Front Tarp Header and in line with the guide rails/skis so the tarp hangs straight down along the guide rails/skis (as shown).

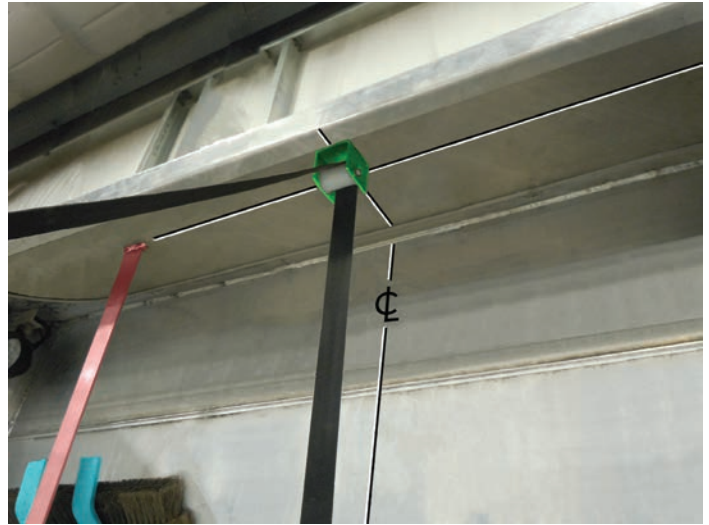

20. Lay the tarp on the floor and **trim equal amounts off the sides** of the tarp so the tarp fits between the side walls. Excessive material will cause improper clean out.

21. Trim the top **2" [50 mm] pipe** 2" [50 mm] shorter than the width of the trailer and insert it in the top pocket. Center the pipe in the pocket and rivet the tarp to the pipe (fasteners not supplied).

22. Trim the UHMW strips (or something similar) to the same length as the top pipe and insert them into the **next two pockets** and rivet or bolt tarp to all of the stiffeners from the bottom side of the tarp. Ensure that the round heads of the bolts or rivets are down against the floor (see installation instructions). **DO NOT** put any additional stiffeners any lower, even if there are additional pockets to do so.

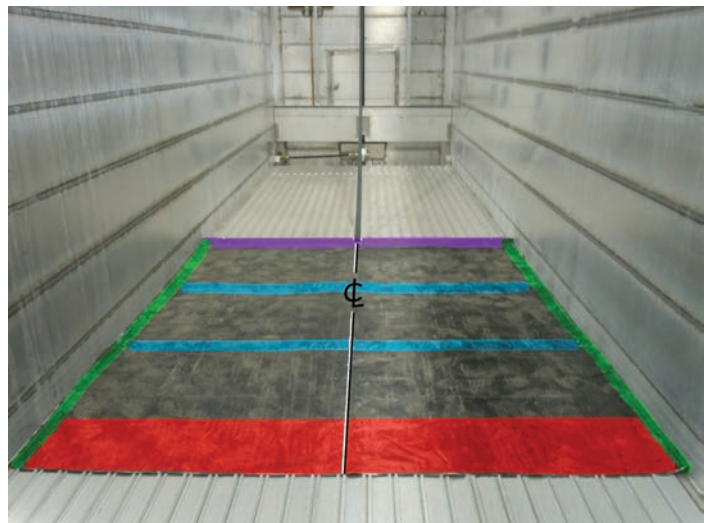

23. Tarp pull out must be adjusted, so that the tarp just touches the ground when at full extension (with the suspension at ride height).



For maximum clean out the tarp should be pulled further out of the trailer so that a minimum of 12" - 24" [305 - 610 mm] of the tarp remains in the trailer. This will cause the tarp to pile up on the ground and potentially get caught up in the unloaded material if steps are not taken to prevent this situation from occurring. **KEITH recommends that a tarp catcher be installed to prevent the tarp from being buried under the unloaded material.**

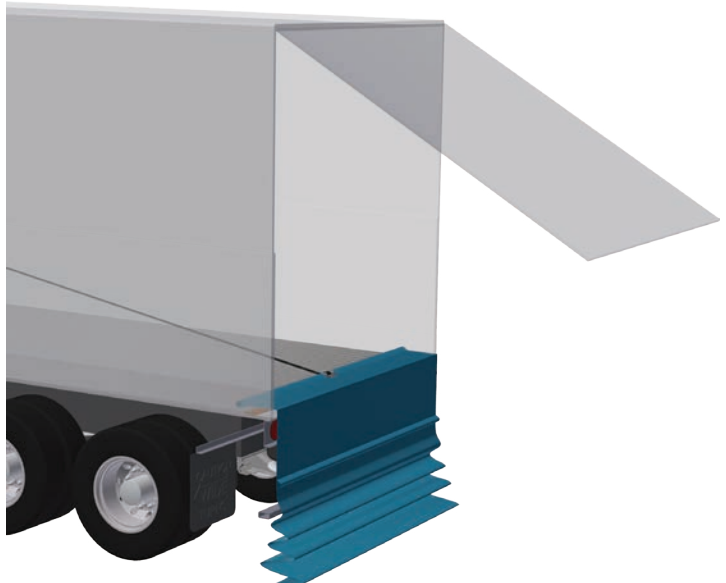

24. Pull (unwind) all of the loose strap completely off of the winch, so the attachment screws are visible, and stretch it out past the end of the trailer, making sure that the strap is not twisted. Cut the strap off, leaving enough strap to wrap around the top pipe. Drill (2) holes through the top pipe, equally spaced from the centerline of the pipe, and use the U-bolt to firmly attach strap to center of pipe. (See Tarp Assembly Instructions)

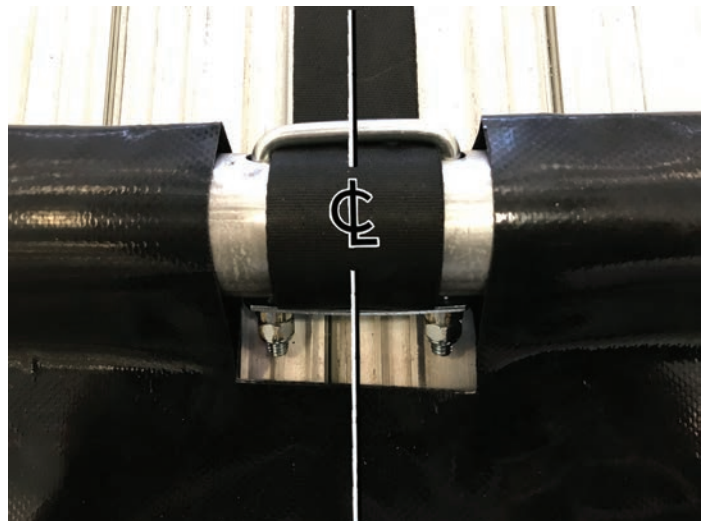

25. Wrap the strap loosely under the u-bolt, around the top pipe, around the u-bolt plate and back up under the u-bolt. Pull tight and tighten the U-bolt to hold the strap securely in place. This will keep the top pipe of the tarp from falling out of the trailer when the strap is fully extended.

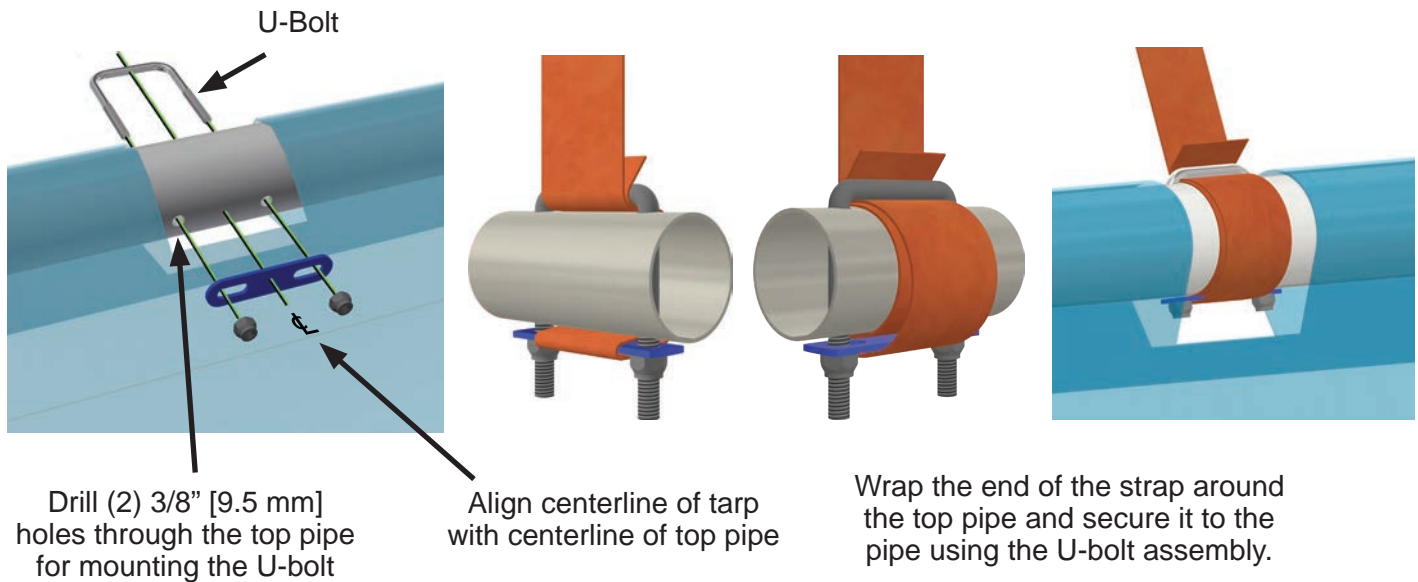

26. Retract the tarp as high as possible. Trim the bottom of the tarp leaving **12"-14" [305 - 356 mm]** laying on the floor. Additional tarp on the floor (36"-48" [914-1219 mm]) may be needed if the material being unloaded is very light weight (low density).



27. Adjust wedge brake on winch. (See Winch Brake Adjustment)

28. Apply safety decals to trailer.

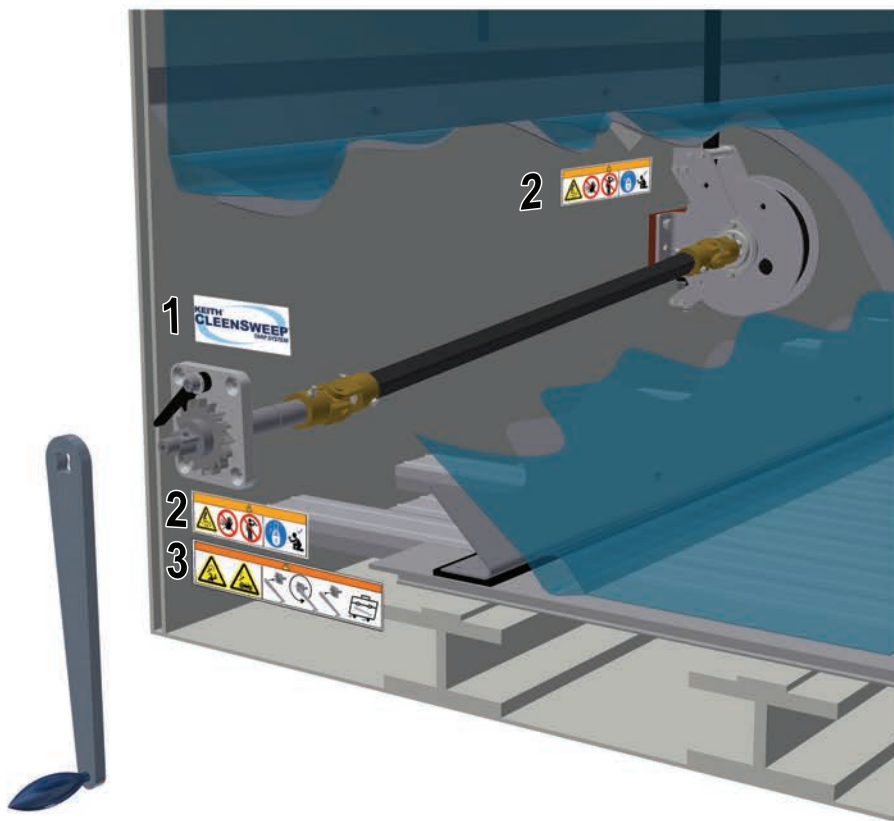
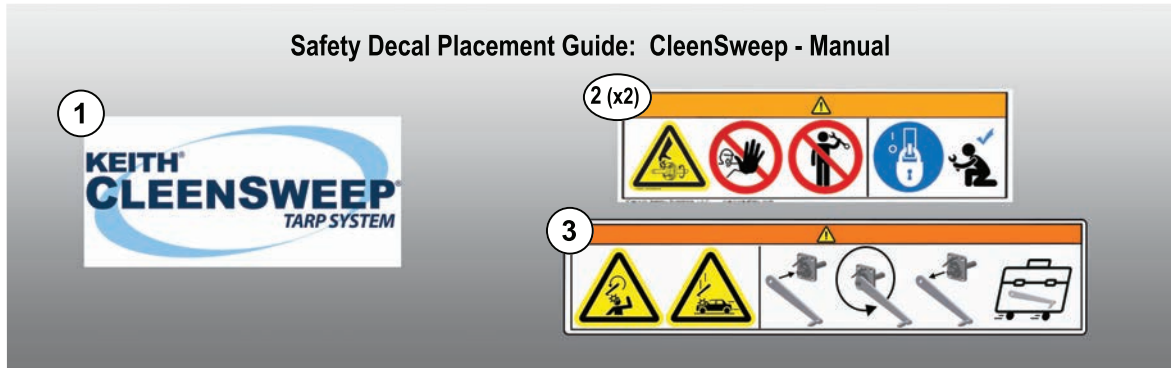

5.0 Winch Brake Adjustment - Wedge Brake

The winch brake retains the tarp in the retracted position at the top of the front wall during loading, transport, and the beginning of the unloading cycle. The brake can be adjusted from the top or the bottom using either pair of jam nuts, whichever side is easiest to access.

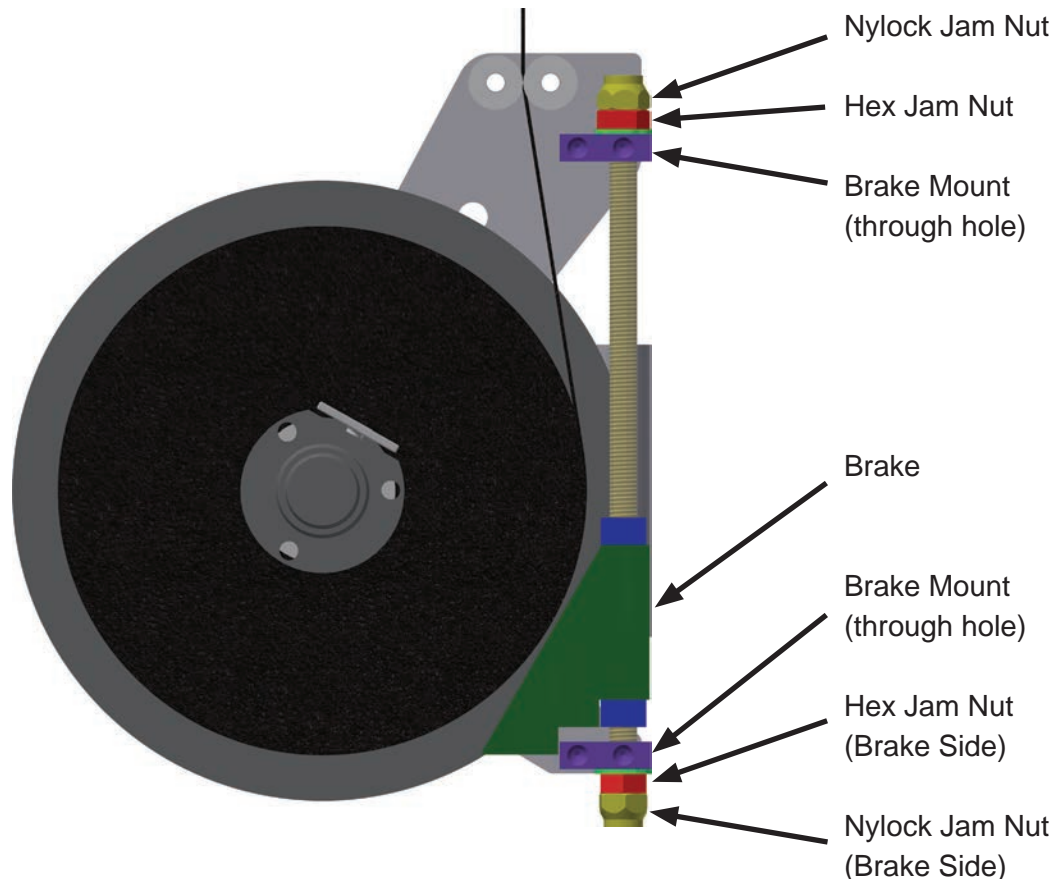

1. Retract the tarp completely to the top of the front wall.
2. Turn whichever pair of jam nuts is easiest to reach, to turn the threaded rod to adjust the brake. A deep socket on a ratchet works well to do this. While turning the jam nut pair, to turn the threaded rod, it can help to put a finger on the wedge brake piece to make sure that the brake is traveling in the direction that you want it to if you can't easily see it. Turn the threaded rod to tighten the brake against the strap until it takes about 10 lbs [5 kg] of force to move the tarp (it should be possible, but take some effort to pull the tarp down by hand).

6.0 Operation

1. **LOADING:** Verify that the tarp is fully retracted with the lever lock engaged in the locking gear and that there is 12"-14" [305-356 mm] of tarp covering the floor slats prior to loading the trailer. It is recommended that a viewing window/port be installed in the top of the front trailer wall so the operator can verify that the tarp is fully retracted from the winch operating position prior to loading.
2. **UNLOADING:** Release the lever lock from the locking gear and turn the *WALKING FLOOR*® on to begin unloading. The gear will turn while the tarp is being pulled out as the material is unloading.

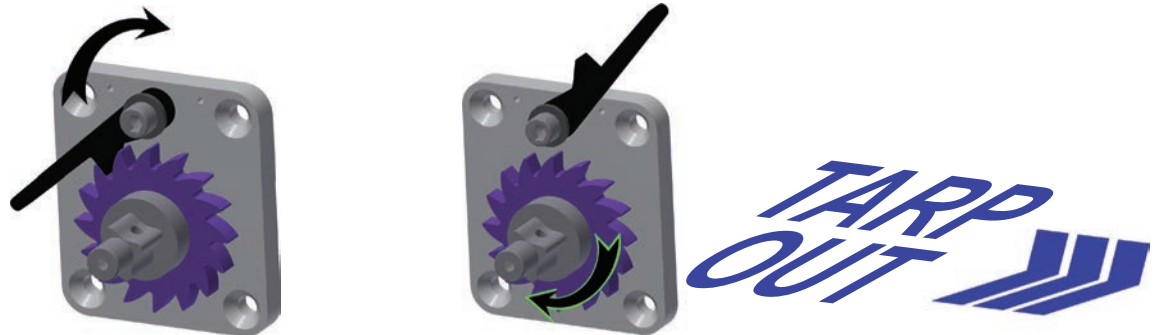

3. **DO NOT let material build up on tarp.** It is recommended that the trailer be moved forward periodically during unloading and especially near the end of the unloading cycle, move it 6'-10' [1830-3050 mm] to prevent material from being unloaded on top of the tarp.

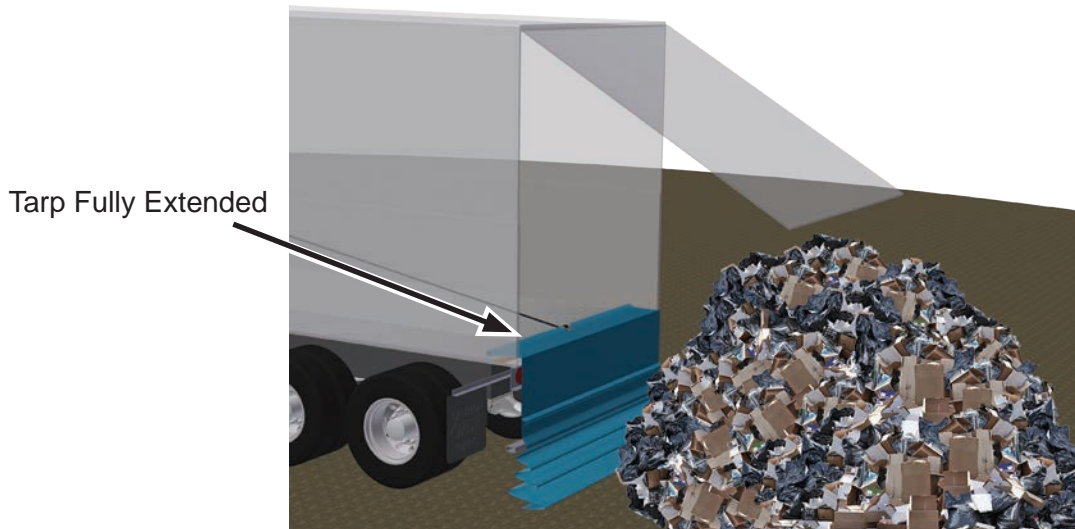

4. After unloading the trailer make sure to stop the floor with all of the slats to the front of the trailer. Dislodge the tarp by hand from underneath any material that may have been unloaded on top of the tarp. **DO NOT attempt to pull the tarp from under a load by using the winch or moving the trailer** – this may damage the winch, tarp, strap or trailer. Installing a tarp catcher (optional) on the end of the trailer will catch and hold the tarp and make sure that it doesn't get buried in the load.

- After the unloading of material is complete, re-engage the lever latch into the gear teeth, attach the crank handle and manually crank in the tarp strap until the tarp is fully retracted to it's highest point and the U-bolt is back up against the strap roller bracket.

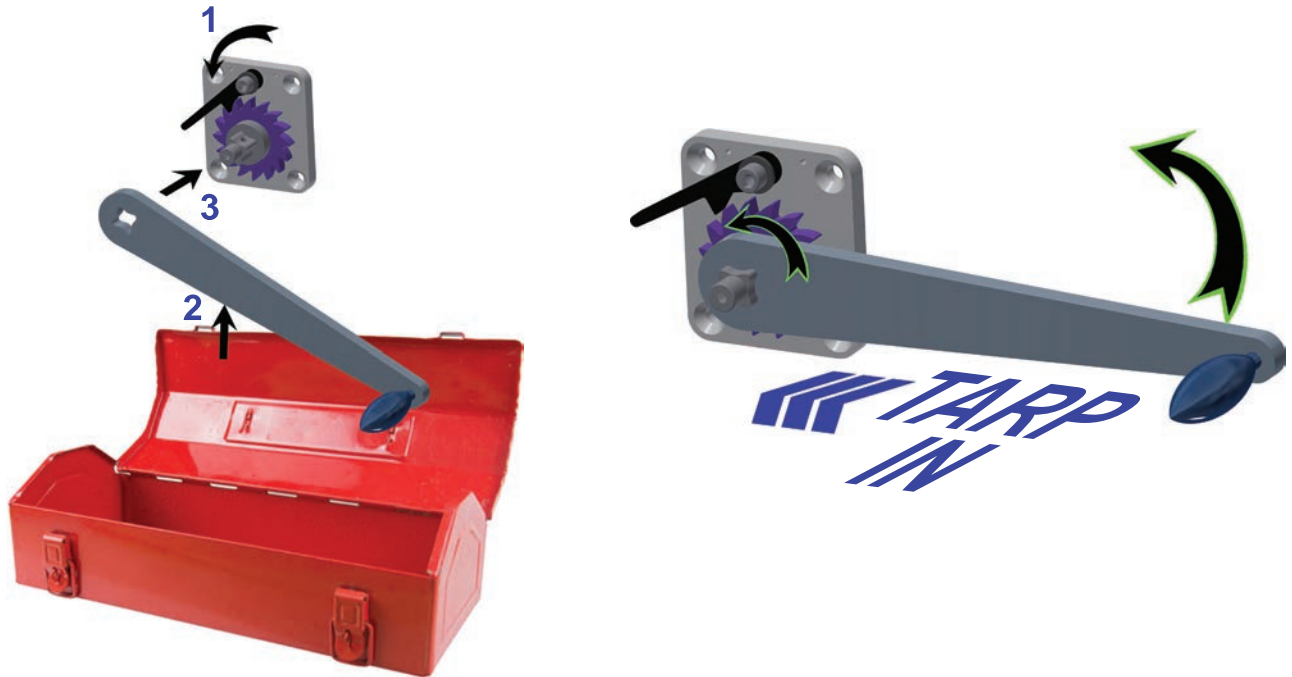

- Ensure that the lever latch is fully engaged in the gear teeth and remove the crank handle and store in a safe location during travel.



7.0 Troubleshooting

7.1 Check List

Before contacting KEITH for technical assistance, please verify the following:

- ✓ Is your system installed as described in the installation instructions?
- ✓ Are there any obstacles that might prevent retraction?
- ✓ Is the brake not adjusted properly and prematurely stopping the tarp?

7.2 Problem / Solution - Troubleshooting

<u>Problem:</u>	Tarp will not stay at the top of the trailer after retracting.
<i>Possible Cause:</i>	Brake is not properly adjusted.
<i>Solution:</i>	See brake adjustment sections for instructions on how to properly adjust the brake.
<i>Possible Cause:</i>	Lever latch is not engaged in gear teeth.
<i>Solution:</i>	See operation sections for instructions on how to properly engage the lever latch.
<u>Problem:</u>	Tarp stops before fully retracting.
<i>Possible Cause #1:</i>	Tarp is getting caught.
<i>Solution:</i>	Remove any obstacles for the tarp.
<i>Possible Cause #2:</i>	Brake is engaging too soon due to improper adjustment or thickening/swelling of strap material due to debris, deterioration/fraying of material or ice build up.
<i>Solution:</i>	Clean or replace the strap or adjust the brake tension.

8.0 Parts Catalog

Winch Assembly

*Serial number must be provided to determine actual part numbers.

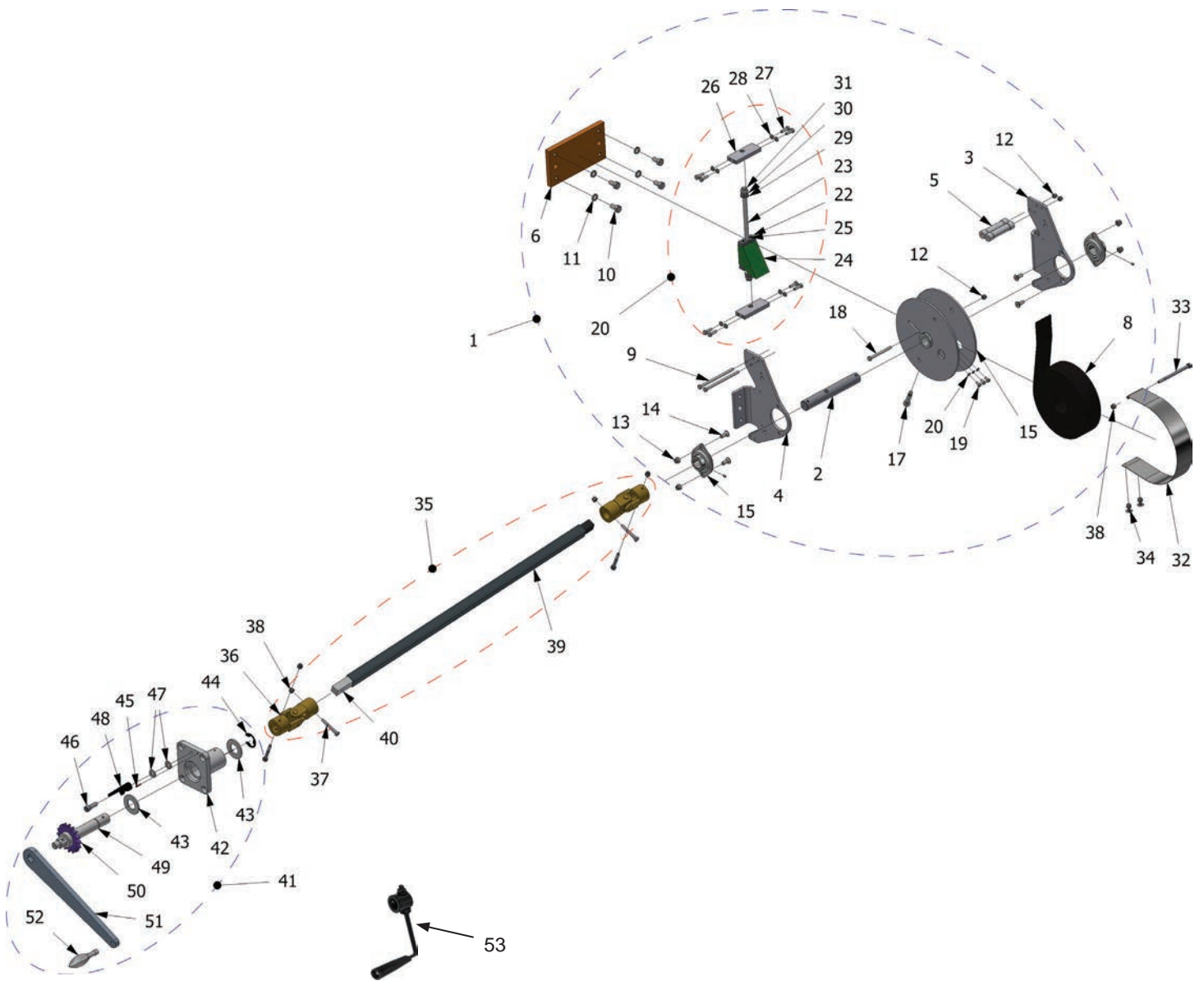

ID #	Qty	USA Part #	Canada Part #	Description
1	-	08609101	8609101	CSM - Manual CleenSweep Winch Assembly (Includes items 1-31)
2	1	07402001	-	SPOOL SHAFT
3	1	08418601	-	MOUNT BRACKET, SWEEP WINCH
4	1	08418603	-	Support Plate for Winch
5	2	08419101	-	STRAP GUIDE
6	1	08551301	-	WINCH BASE PLATE, AL, UNIVERSAL MOUNT
8	2	85811075	-	STRAP POLYESTER 2" X 75' (+/- 10")
9	2	87005101	-	Hex Bolt - M6 x 1 x 110
10	4	87008470	-	Hex Bolt - M10 x 1.5 x 20
11	4	87076500	-	Lock Washer - M10
12	3	87100500	-	NUT HEX NYLOCK 6mm
13	4	87101000	-	NUT HEX NYLOCK 8mm
14	4	87701599	-	Hex Socket Countersunk Head Cap Screw - M8x20
15	2	85818617	-	BEARING FLANGE 2-BOLT
-	2	w/Bearing	-	Hex Socket Set Screw - Flat Point - 10-32 UNF x 0.25
16	-	08549601	-	Spool Assembly, Welded
-	1	08549701	-	SPINDLE, WINCH SPOOL, BOLT-ON FOR WINCH #08387701
-	2	08549801	-	SIDE PLATE, WINCH SPOOL
17	1	06175401	-	Socket Head Shoulder Screw - ANSI B18.3.3M - M8x1.25 x 43.25
18	1	87004570	-	BOLT HEX GR8.8 6MMx70MM
19	3	87009009	-	Hex Socket Button Head Cap Screw
20	3	96550552	-	Flat Washer
21	-	10310401	-	Brake Assembly, 262mm All Thread (Includes items 22-31)
22	2	08418801	-	BRAKE HOLDING NUT FOR WINCH #08387701
23	1	08553901	-	ALL THREAD, 10MM X 262MM, CS
24	1	09095201	-	BRAKE, 30 DEGREE ANGLE, FOR CS WINCH
25	4	86651425	-	PIN ROLL 1/4"X1" ZINC
26	2	08418901	-	BRAKE HOLDING MOUNT, CLEENSWEEP
27	8	87002500	-	Hex Bolt - M6 x 1 x 20
28	8	87075500	-	Lock Washer - M6
29	2	87076000	-	WASHER FLAT 10MM
30	2	87101500	-	NUT HEX 10MM
31	2	87102000	-	NUT HEX NYLOCK 10mm
32	1	-	ND:70000014	Strap Cover - 1/16" Galvanized Plate (16 gauge)
33	1	86423000	BB ND:CSH8C14-4P	Bolt Hex Cap 1/4"x4" GR8 NC
34	2	-	T435	POP RIVET BLIND AL LARGE FLANGE 3/16x1/2
35	-	10188301	-	Drive Shaft Assembly (Includes items 36-40)
36	2	84609214	ND:70000010	U-JOINT HIGH TORQUE 1.5" ROD
37	4	86423000	BB ND:CSH8C14-2P	Bolt Hex GR8 1/4"x2"
38	4	86626000	86626000	NUT HEX NYLOCK 1/4"
39	1	08894401	ND:70000013	Drive Shaft Fixed End
40	1	08894501	C60000383	Drive Shaft Slip End

ID #	Qty	USA Part #	Canada Part #	Description
41	-	10762701	-	Manual Crank Handle Assembly (Includes items 42-52)
42	-	10187401	-	Cross Shaft Mount Weld Assembly
-	1	08657301	8657301	Cross Shaft Mounting Plate
-	1	08894001	ND:60000384	Bearing Tube - Crank Handle Shaft
-	1	08893901	ND:70000019	BEARING SPACER
-	2	-	ND:60000441	NEEDLE BEARING 1"
-	1	-	T180	GREASE FITTING 1/4"-28 THREAD
43	2	86562000	ND:60000436	WASHER FLAT 2"X1" ID
44	1	-	ND:70000027	E-CLIP 1"
45	1	86650260	ND:60000429	ROLL PIN 1/8"X5/8"
46	1	86437520	ND:60000440	SHOULDER BOLT SOCKET HEAD 3/8"X1"
47	2	86554001	BB ND:FW838ZD	WASHER FLAT 3/8 SAE
48	1	08247801	8247801	GEAR LOCK LEVER, 3/8" STEEL PLATE, KMD MINI WINCH
49	1	10769201	10769201	SPLINED SHAFT FOR MANUAL WINCH HANDLE
50	1	10769301	10769301	MANUAL WINCH, CRANK GEAR (16 TOOTH), 1.375" ID
51	1	10769101	10769101	MANUAL WINCH, SPLINED CRANK HANDLE - SAE
52	1	-	ND:60000529	SWIVEL HANDLE THREADED SHAFT
53	1	-	3008176A	Crank Handle - Mini Replaces #51-52 (Optional)

Strap Roller Assembly

06250301 - Universal Mount

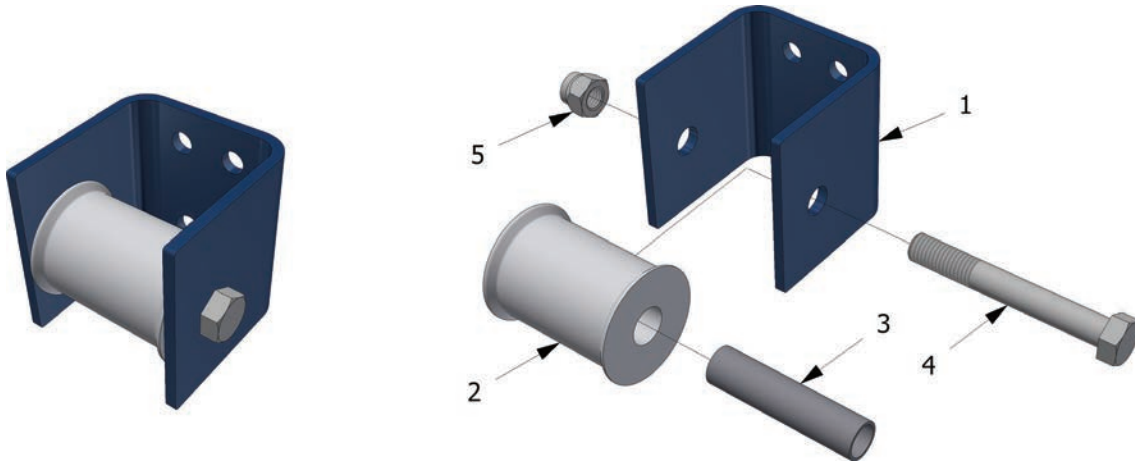

ID #	Qty	Qty	USA Part #	Description
-	-	-	6250301	STRAP ROLLER ASSEMBLY, AL - METRIC (Includes items 1-5)
-	-	-	6250302	STRAP ROLLER ASSEMBLY, SS - METRIC (Includes items 1-5)
1	1	-	06250401	STRAP ROLLER BRACKET UNVL CSH KSH AL
	-	1	06250402	STRAP ROLLER BRACKET UNVL SS -CSH UNIVERSAL MOUNT
2	1	1	05795501	STRAP ROLLER CSH
3	1	1	05813401	STRAP ROLLER BUSHING CSH
4	1	1	87013400	BOLT HEX 10.9 12MMX90MM
5	1	1	87102500	NUT HEX NYLOCK 12MM-1.75 ZINC

Tarp & Misc Components

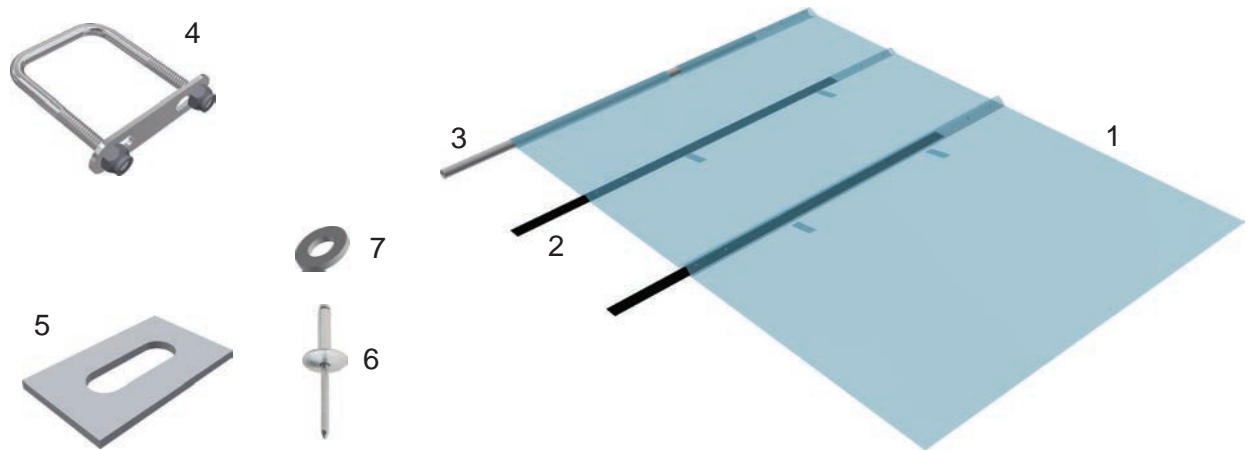

ID #	Qty	USA Part #	Canada Part #	Description
1	1	09169001	-	TARP, 18 OZ. VINYL, TRIM-TO-FIT (STANDARD)
2	2	03540150	3540150	UHMW STRIP FRONT SHIELD 96" 1/4 X 2-7/8 W/ HOLES
3	1	-	ND:60000214	POLE 1-7/8' X 90"
4	1	86671100	86671100	BOLT U SQ ASSY 5/16X2X3 11302, WASHER PLATE & NUTS
5	1	-	ND:60000383	UHMW STRAP GUIDE
6	2	-	ND:60000442	POP RIVET BLIND AL LARGE FLANGE 3/16"x5/8" (STRAP GUIDE)
	10	-	ND:60000076	RIVET BLIND STEEL 3/16"X1/2" (TARP TO STIFFENERS)
7	10	-	ND:60000494	WASHER 3/16" AL (BACK-UP FOR TARP RIVETS)

Tarp Catcher™



Part # 12306001

9.0 Technical Support

Please have the following information readily available before contacting KEITH Manufacturing Co. for support:

- Model Number (Located on the Serial Plate of the unit or engraved)
- Serial Number (Located on the Serial Plate on the unit or engraved)
- Vehicle make and unit installer

KEITH Technical Support Contact Information - Canada:

Website: www.WalkingFloorService.ca

Toll-Free: 800-514-6085

Phone: +1-519-756-9178

KEITH Technical Support Contact Information - USA:

Website: www.KeithWalkingFloor.com

Email: TechDept@KeithWalkingFloor.com

Toll-Free: 800-547-6161

Phone: +1-541-475-3802

10.0 Contact Information - KEITH Manufacturing Co.

WALKING FLOOR® International

Canada

Brantford, ON

Toll-Free: 800-514-6085

Phone: +1-519-756-9178

Email: CanadaSales@KeithWalkingFloor.com

World Headquarters - USA

401 NW Adler St.

Madras, OR 97741

Toll-Free: 800-547-6161

Phone: +1-541-475-3802

Email: Sales@KeithWalkingFloor.com

11.0 Crank Handle Mounting Plate Template

(PRINT TO SCALE)

